



Bronco Models

Kit No. CB-35109

Russian Self-Propelled Gun SU-152(KV-14) [September, 1943 Production] 1/35 SCALE

俄军 SU-152 (KV-14) 【1943年9月生产型】



The Red Army entered WWII with most of its heavy artillery drawn by horses, making its movement slow and vulnerable to attack. The KV-2 assault gun was built to address the need for mobile artillery, but it was unsatisfactory as a fighting vehicle, mainly because of its large and overweight turret. It was therefore decided to replace the KV-2 with a new vehicle based on the KV-1S chassis. But instead of a turret, the 152mm ML-20S gun-howitzer would be mounted in a low profile casemate. Several designs were put forward, but the KV-14 showed most promise and was further developed into the SU-152 by February 1943. This self-propelled gun weighed 45.5 tonnes and had frontal armour up to 75mm thick, powered by a 600bhp V-2K diesel engine it had a top speed of 43km/h. It was built at the Chelyabinskii Kirovskii factory until replaced in production by the ISU-152 in December 1943. Though designed as an assault gun, it gained a reputation as a "Tiger Killer", as the huge blast of the 152mm shell could blow the turret clean off the German tank! 🇬🇧

Short Story by Phil Greenwood

Die rote Armee trat in den zweiten Weltkrieg mit größtenteils von Pferden gezogener schwerer Artillerie ein. Diese war dadurch sehr langsam und verwundbar. Der KV-2 war ein Versuch, diese Nachteile zu vermeiden. Jedoch war er aufgrund des hohen und schweren Turmes nicht sehr erfolgreich. Daher entschied man sich für eine neue Entwicklung basierend auf dem KV-1S Fahrwerk. Anstelle eines Turmes montierte man die 152mm ML-20S Kanone in einem niedrigen Kastenaufbau. Verschiedene Entwürfe folgten, und der viel versprechende KV-14 wurde bis Februar 1943 zum SU-152 weiter entwickelt. Diese Selbstfahrlafette wog 45,5 Tonnen und war am Bug bis zu 75mm gepanzert. Der 600 PS V-2K Dieselmotor erlaubte eine Höchstgeschwindigkeit von 43 km/h. Der Panzer wurde in der Chelyabinskii Kirovski Fabrik gebaut, bis er im Dezember 1943 vom ISU-152 ersetzt wurde. Obwohl man die SU-152 als Sturmgeschütze bezeichnete, erwarben sie sich den Ruf der „Tiger Jäger“, denn ein Treffer konnte den kompletten Turm des deutschen schweren Kampfpanzers vom Rumpf reißen. 🇩🇪

© Translation Michael Knoblich Academy Europe

在二次大战初期不少苏联红军的重炮是由马匹所拉动，引致它的机动性不足和极易遭敌人所攻击。KV-2 突击炮是按这需要而被打造出来，但是它的表现却令人非常失望，主要问题在于它的过大和超重的炮塔。因此当局决定用 KV-1S 的底盘开发一辆全新的自走炮去替换 KV-2。主要的设计要求是将 152 毫米 ML-20S 榴弹炮装在一个低矮的车身上。几个不同的设计被提交了。在 1943 年 2 月，被命名为 KV-14 的设计却为当局所接受而进一步被开发成 SU-152 自走炮。这台自走炮重约 45.5 吨，它最高时速可达 43 公里，前面装甲有 75 毫米厚，动力由一具 600bhp V-2K 柴油引擎所提供。此车一直在 Chelyabinskii Kirovskii 工厂生产直至在 1943 年 12 月被 ISU-152 所代替为止。其设计虽为突击炮，但它却赢得了“老虎杀手”的称号，因为 152mm 弹药的巨大威力可将一辆德国坦克的炮塔轰掉！ 中文

ILLUSTRATION 图示说明:

CORRECT METHOD FOR APPLYING DECALS : HINWEISE ZUM ANBRINGEN DER DECALS : 正确使用水贴纸的方法:

1. Clean model parts surface with wet cloth. Entsprechende Stellen am Modell feucht reinigen.
将需要贴水贴之部位表面擦干净。
2. Cut out the decal parts and dip them in cold water for 15 ~20 seconds. Decal ausschneiden und für 15-20 Sek. ins Wasser legen.
将所需之贴纸剪下泡在清水里约15至20秒。
3. Place it on correct position of the model kit. Decal an der richtigen Stelle auflegen.
将湿透之贴纸取出置放于正确之位置旁。
4. Slide off the decal from the base paper on to the model kit surface with a cotton stick. Decal mit Wattestäbchen festhalten und Papier darunter wegziehen.
用棉花棒轻推贴纸表面使其从底纸滑出至模型表面之正确位置。
5. When decal get dry then complete. Decal mit Papiertuch andrücken und trocknen.
待其自然干透后即完成。

ICON INSTRUCTION: 图标说明:



Open Hole
Loch bohren
钻孔



Remove
Abtrennen
切除



2 Sets needed
Vorgang wiederholen
同样的制作二组



Bend
Biegen
曲折



Optional
Auswahl
可以选择采用



Apply Decal
Decal anbringen
贴水贴纸



Instant Glue For Metal
Sekundenkleber verwenden
瞬间接着剂,金属用



Fill Hole
Verspachteln
把孔填平



Do not cement
Nicht kleben
不用粘合

Color 涂料表			MR. Hobby	Hobby Color	Humbrol	Tamiya
Steel	Stahl	黑铁色	H-18	C-28	53	/
Wood brown	Dunkelgrün	木棕色	H-37	C-43	/	/
Flat black	Mattschwarz	消光黑	H-12	C-33	33	XF-1
German gray	Deutsch grau	德国灰	H-32	C-40	92	XF-63
Silver	Silber	银色	H-8	J-8	11	X-11
Oliver darb	Braun-Olive	橄榄褐	H-304	C-304	116	TS-28
Tyre black	Reifenschwarz	轮胎黑	H-77	C-137	85	/
Flat white	Weiss	消光白	H-11	C-62	34	XF-2

READ BEFORE ASSEMBLING: VOR ZUSAMMENBAU LESEN: 组装必读:

- Carefully Study instruction before assembling. Anleitung studieren und verständlich machen. 组装前请阅读清楚制作指引。
- Keep plastic model glue and tools away from children. Kleber, Farben, Werkzeuge und Plastiktüten von Kindern fernhalten. 胶水,油漆及工具勿让小孩接触。
- Do not use cement or paint near open flame or sparks. Kleber/Farbe nicht in Nähe von offenen Flammen. 胶水及油漆勿接触火种。
- Do not work in closed room. Nur in ausreichend belüfteten Räumen arbeiten. 勿在密封地方制作模型。

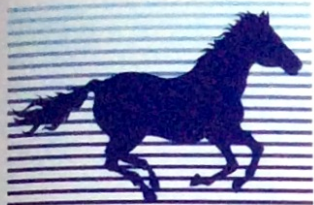

BRONCO

Bronco Models

Copyright © 2012

Made in China

中国制造

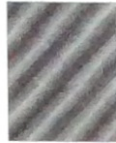

No use parts
不要部件

(D) × 1

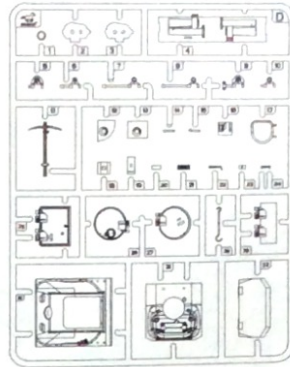

(Da) × 1

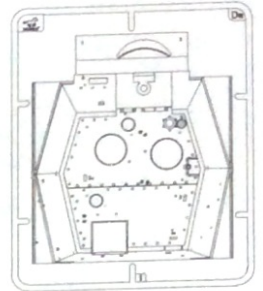

(A) × 1

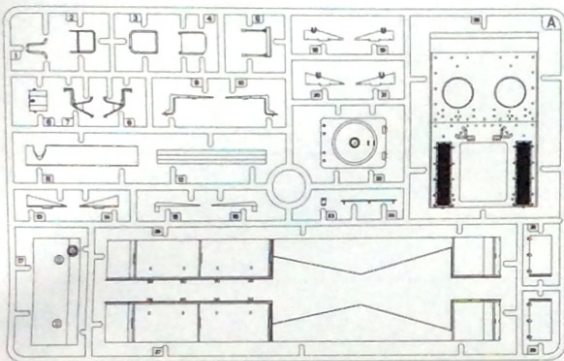

(Ga) × 2

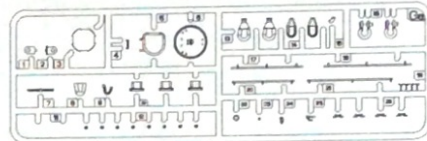

Copper wire × 2
铜丝



(Ge) × 2



(Gb) × 2

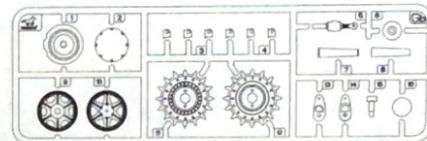

(F) × 1



(B) × 1

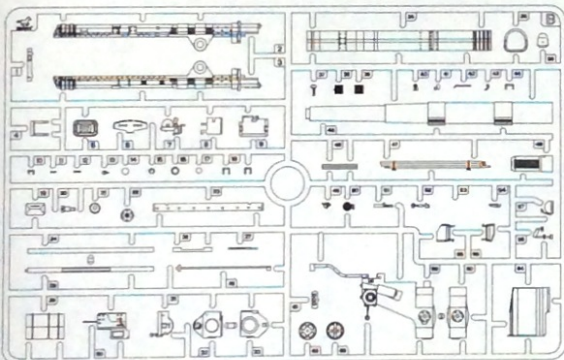

(L) × 18



(R) × 10



(Cd) × 13

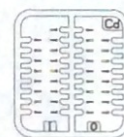

(M) × 1

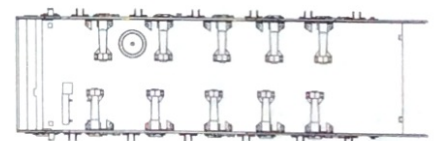

(Ca) × 1

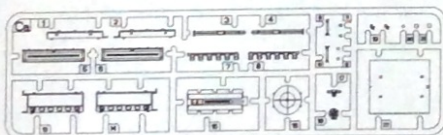

DECAL × 1



(Cb) × 6

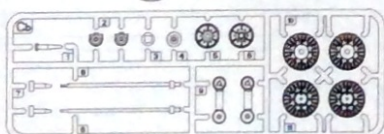

(P) × 1



CB35109

ILLUSTRATION 图示说明:

- 1** Caution:
This kit contents a lot of small accurate parts, please carefully to read before to assembly.
此套件包含不少精细零件, 请在制作前先翻阅说明书了解清楚。

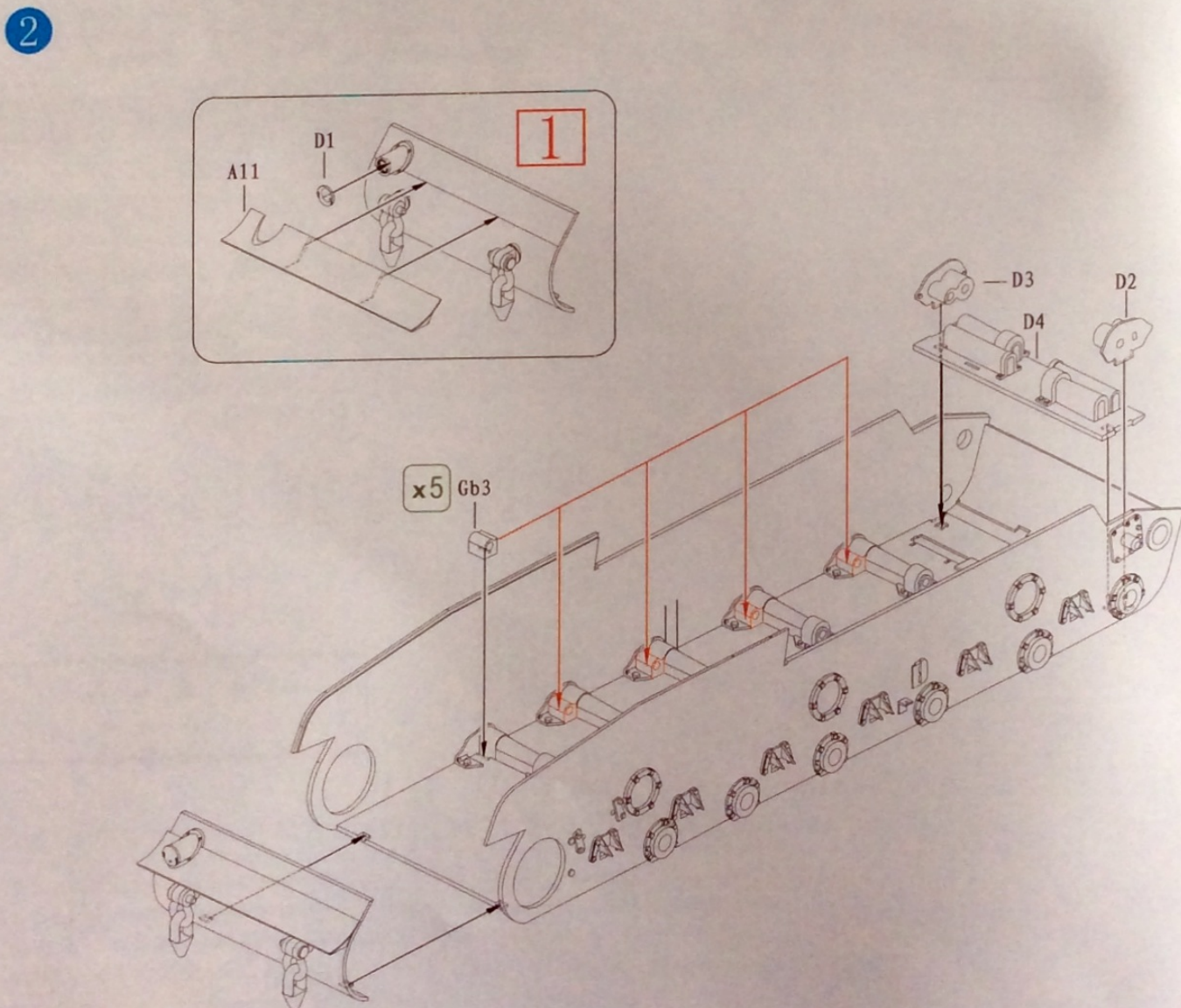
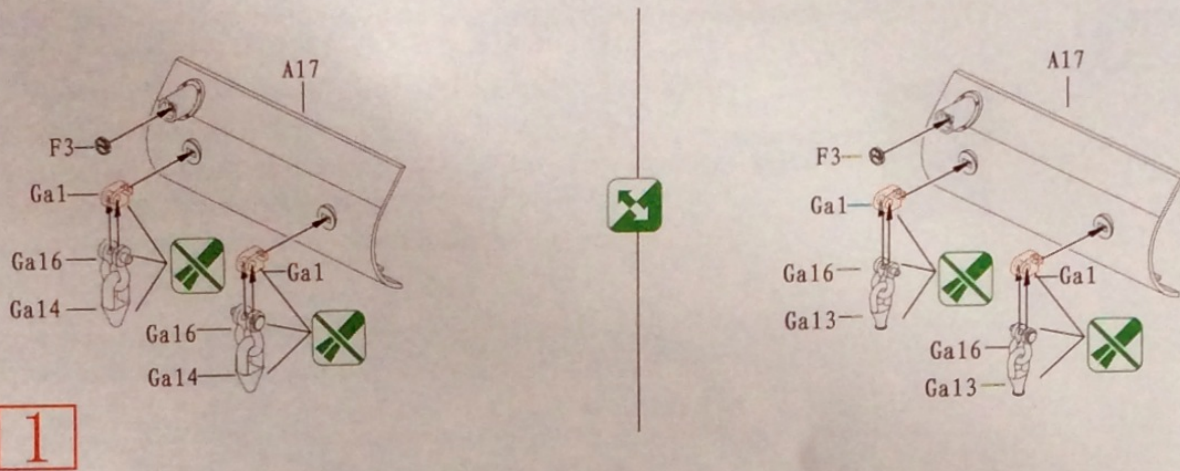

3

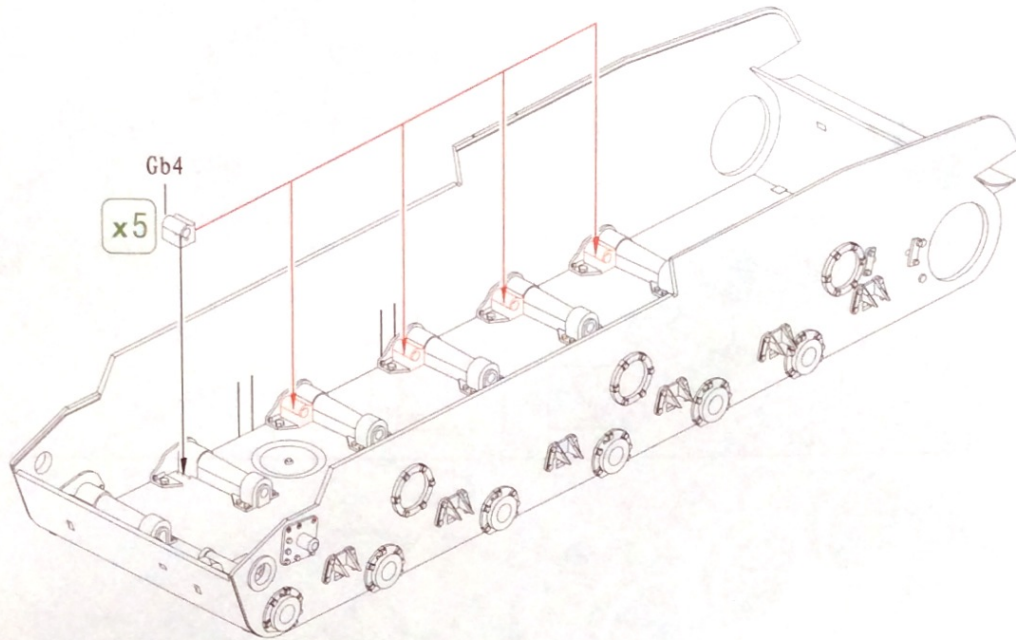

4

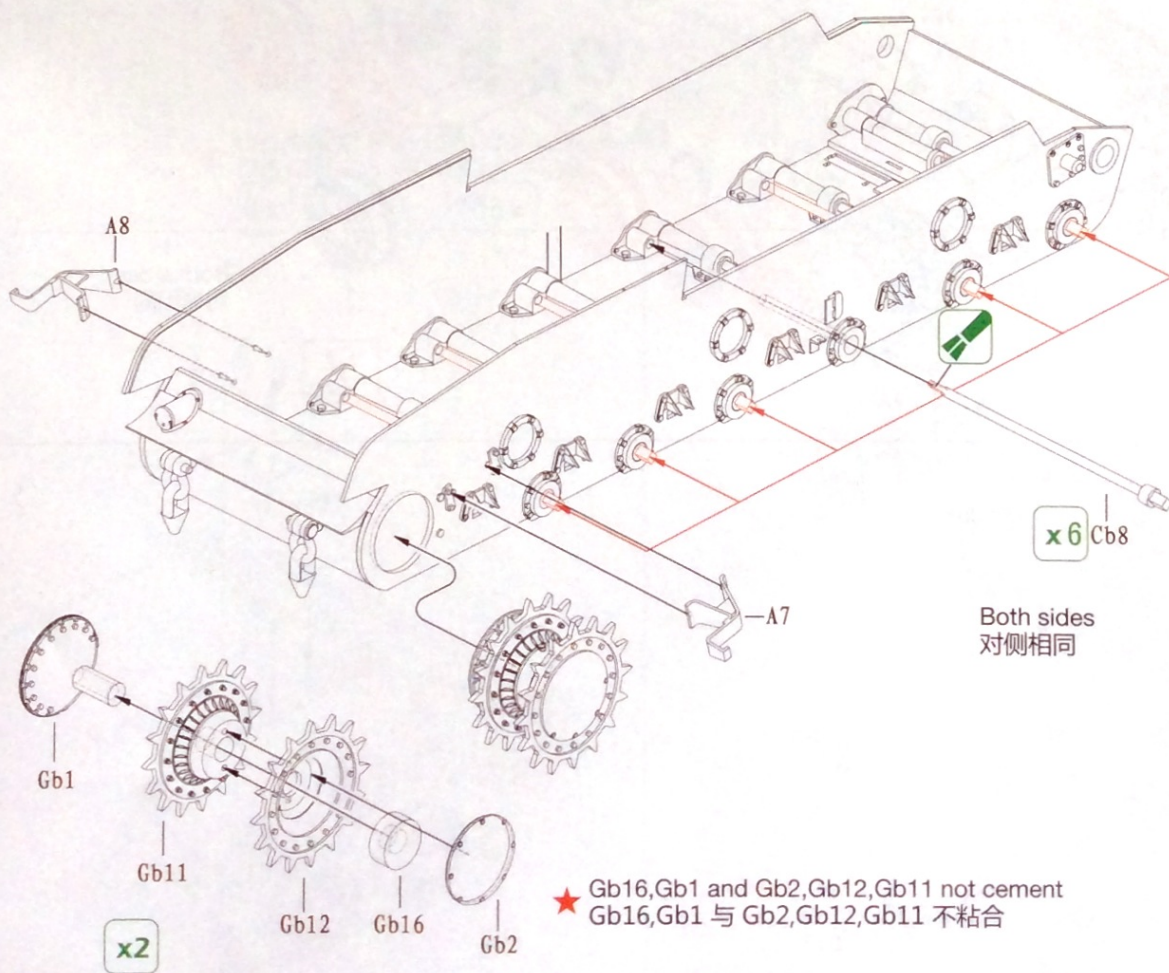
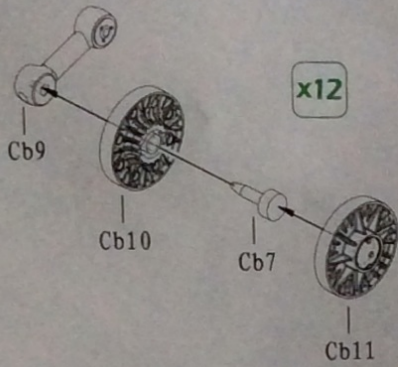

ILLUSTRATION 图示说明:

5

★ Cb7,Cb9 and Cb10, Cb11 not cement
Cb7,Cb9 与 Cb10,Cb11 不粘合



2

★ Gb15,Gb13 and Gb9, Gb10 not cement
Gb15,Gb13 与 Gb9,Gb10 不粘合

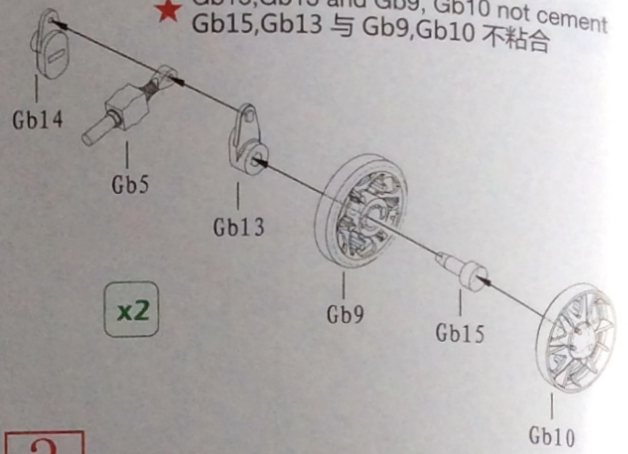

3

6

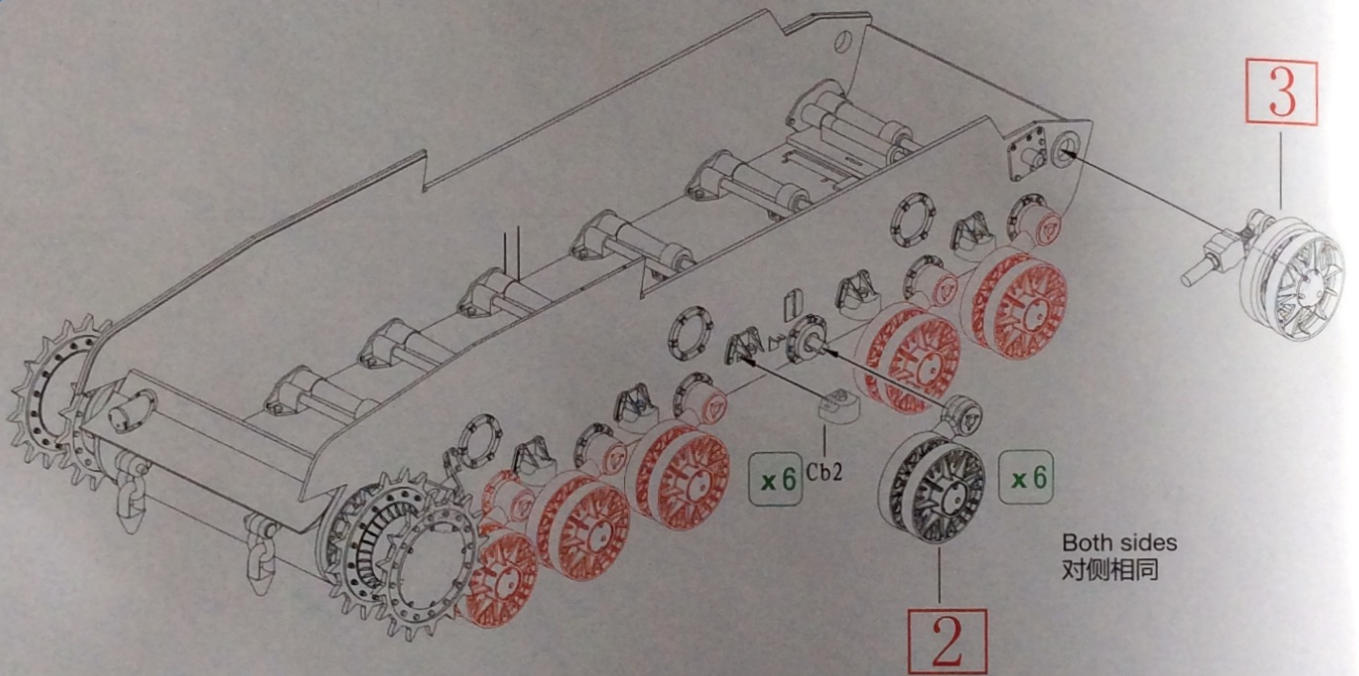

2

7

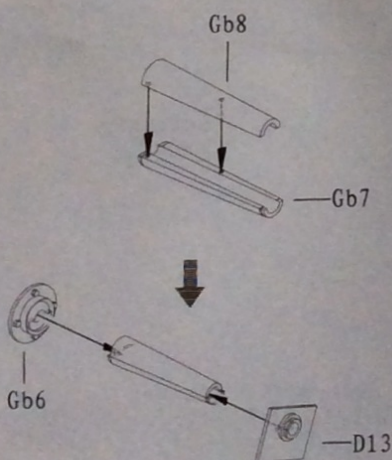

4

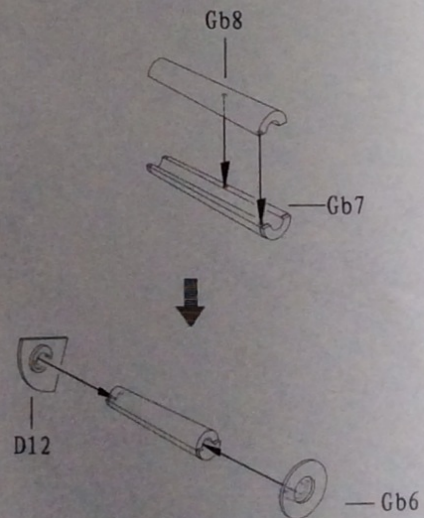

5

8

Close position
关闭状态

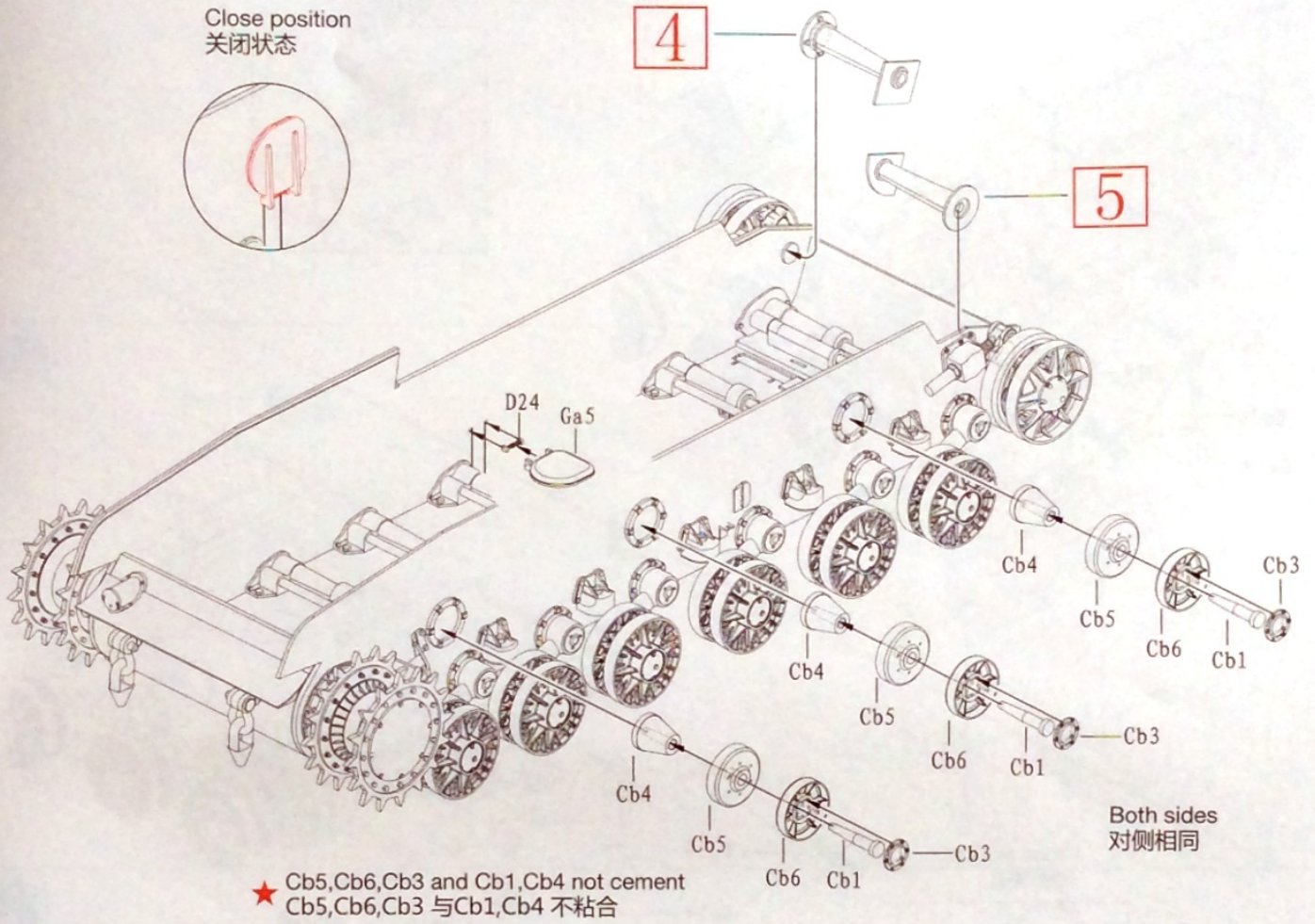
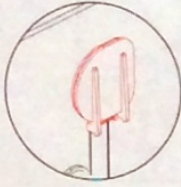

Both sides
对侧相同

★ Cb5,Cb6,Cb3 and Cb1,Cb4 not cement
Cb5,Cb6,Cb3 与Cb1,Cb4 不粘合

9

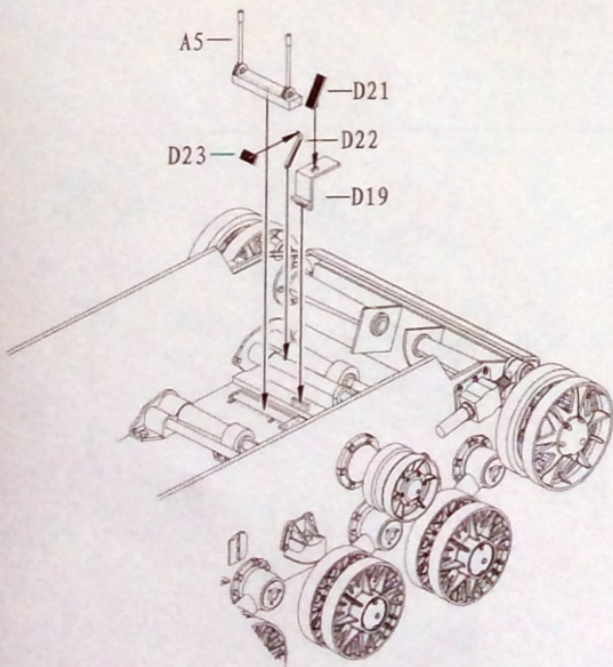

10

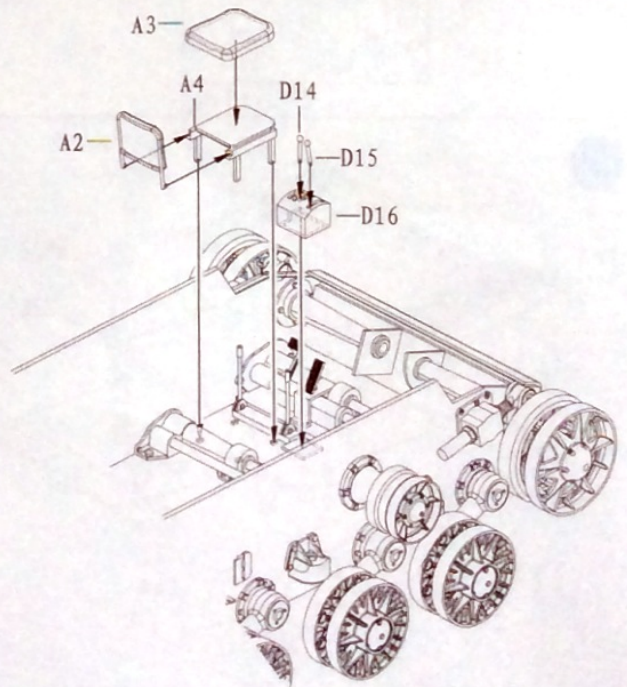
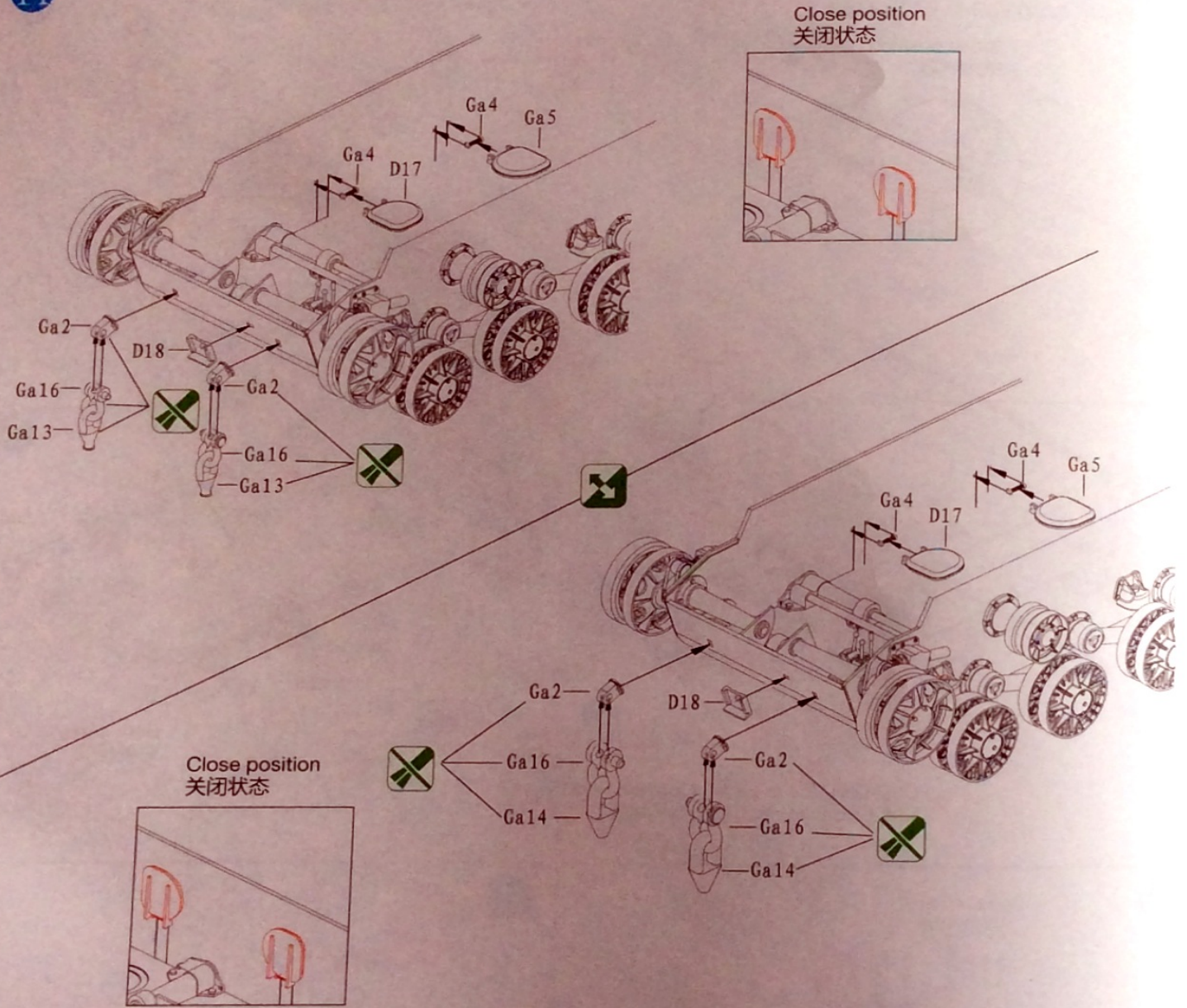
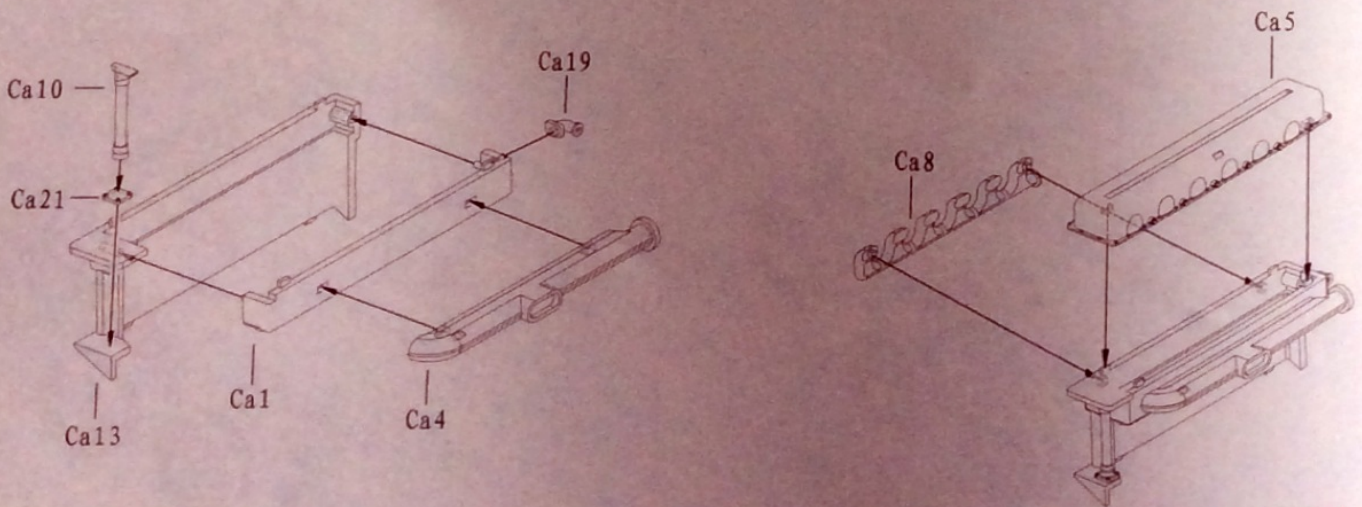

ILLUSTRATION 图示说明:

11



12



6

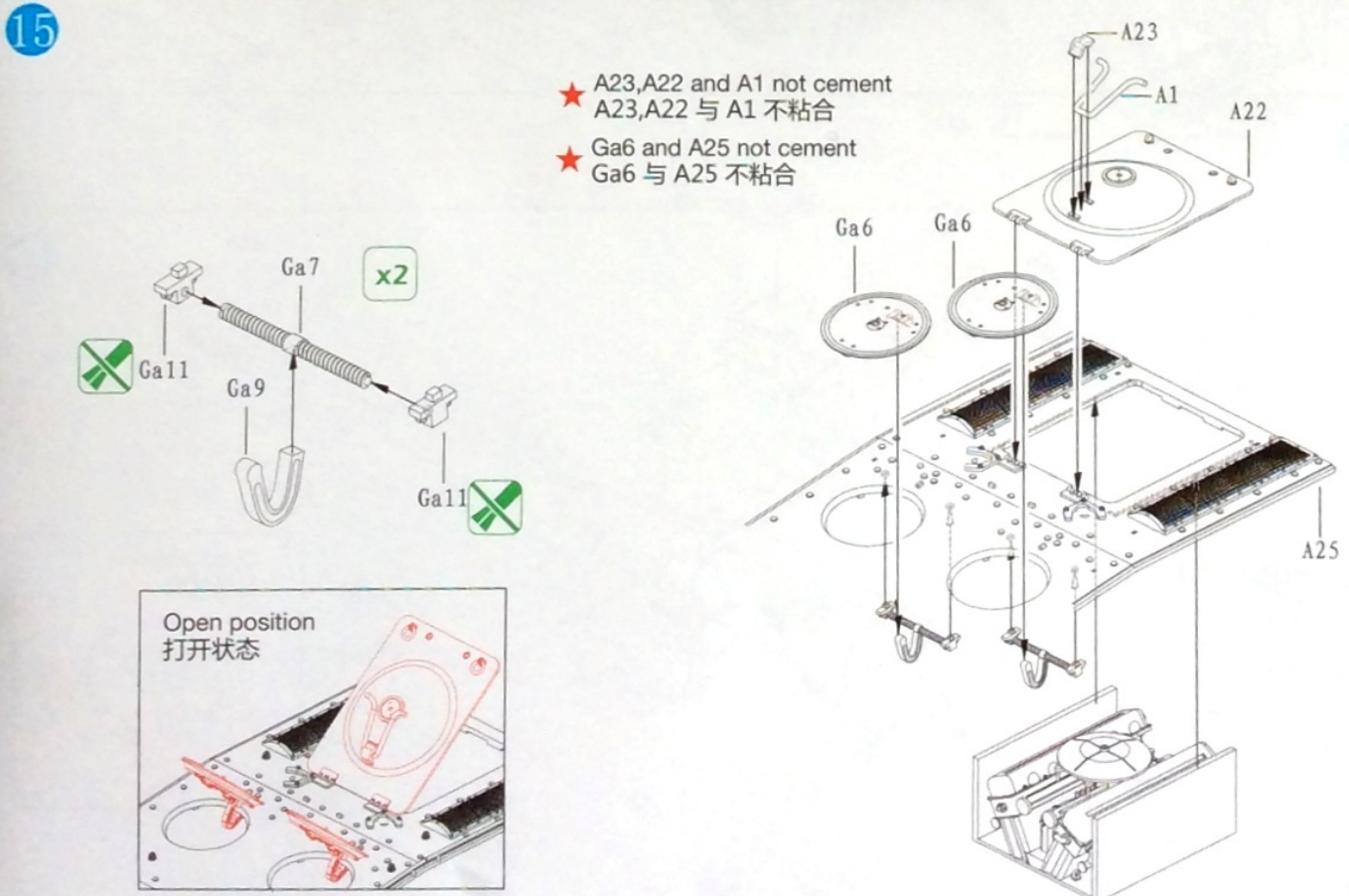
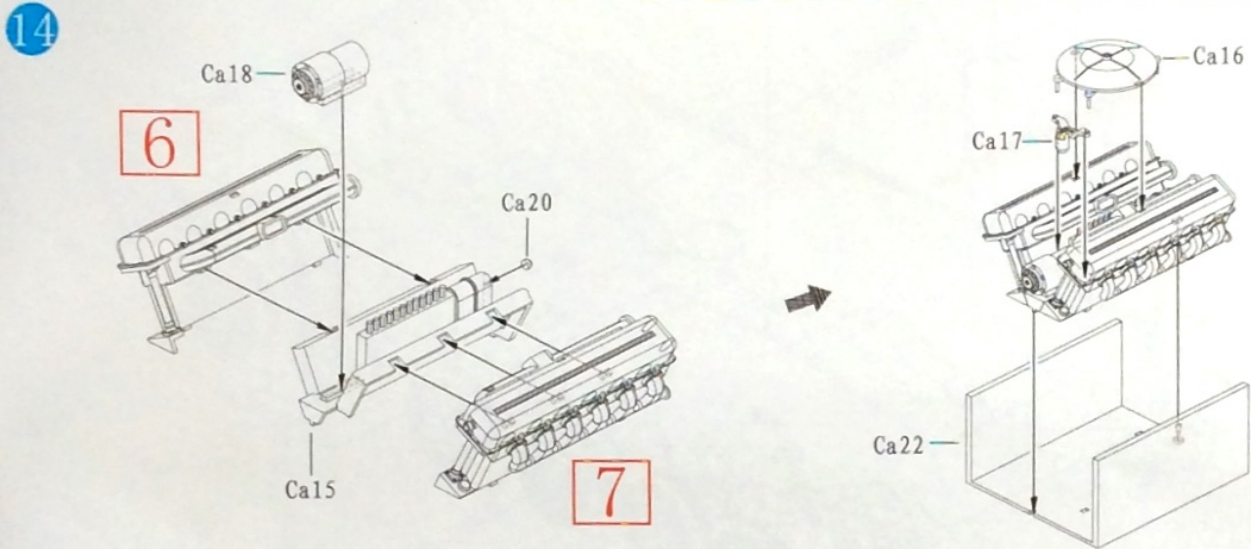
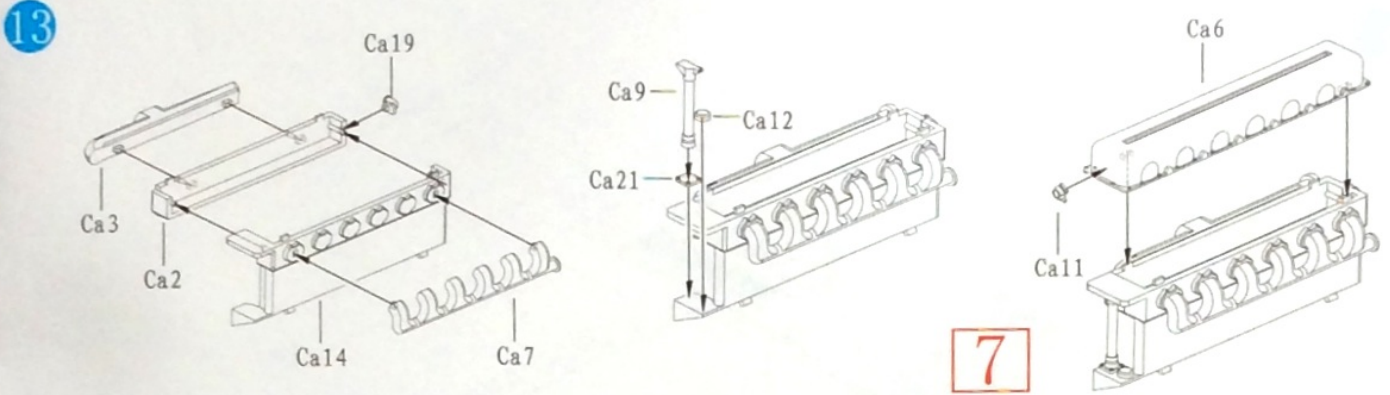
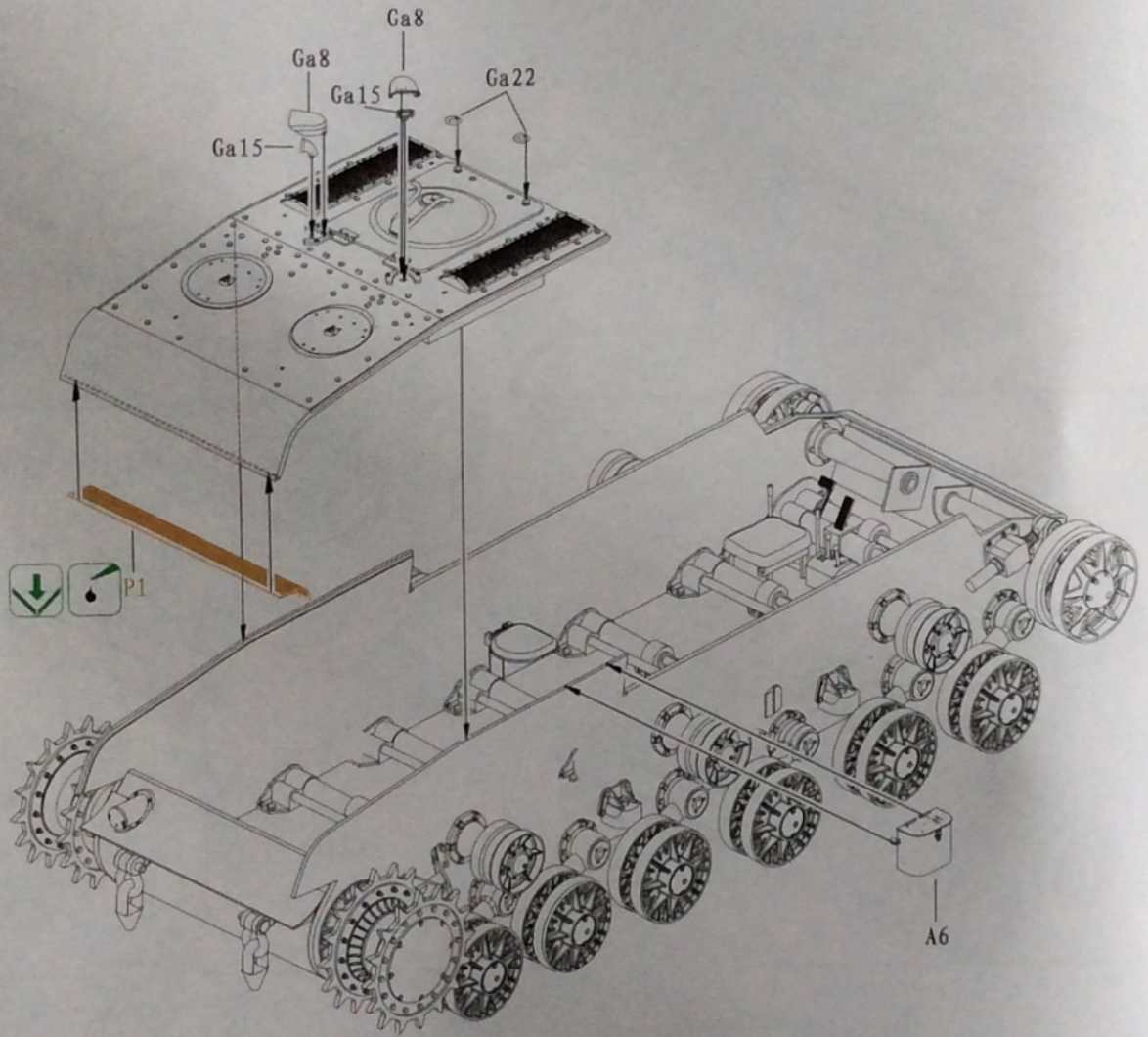
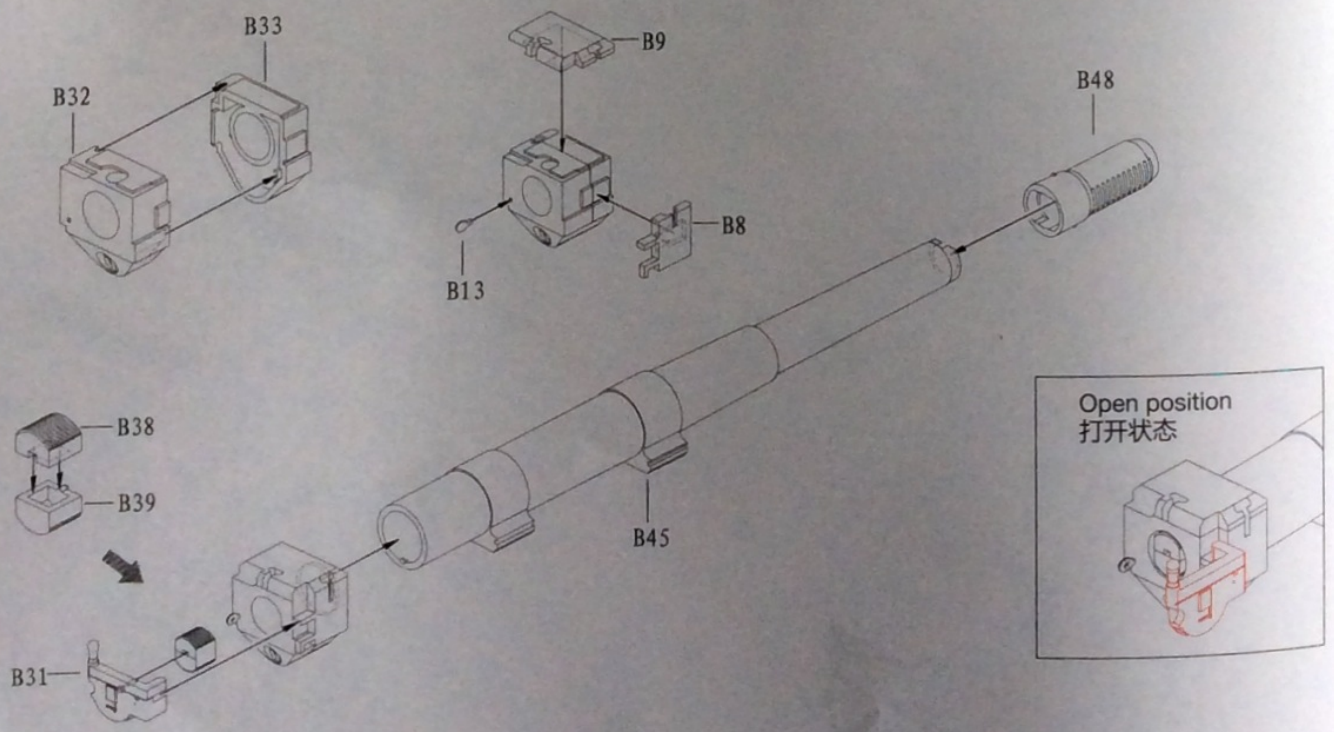

ILLUSTRATION 图示说明:

16



17



18

★ B24, B25 and B28 not cement
B24, B25 与 B28 不粘合

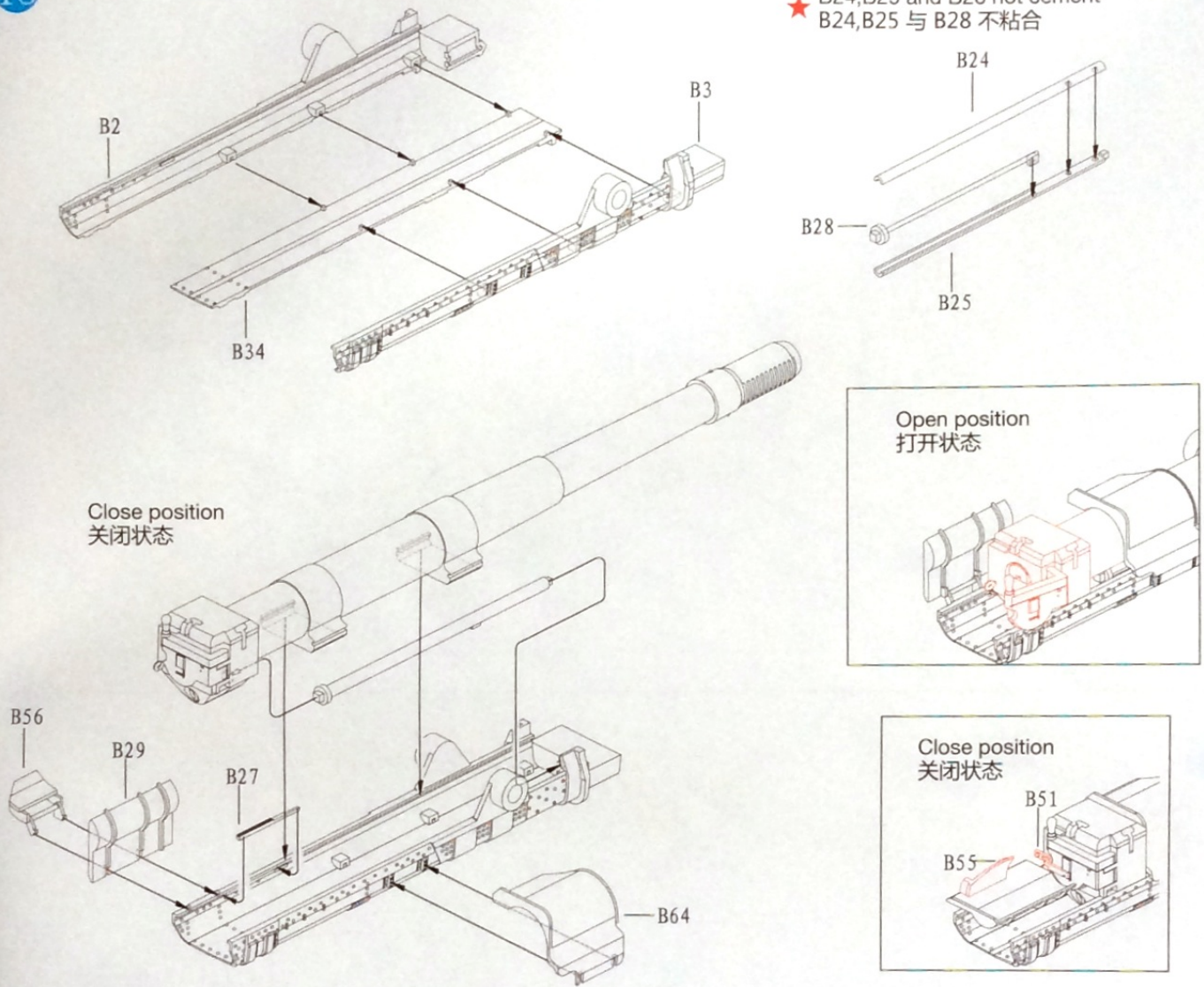

19

★ B14, B59 and B21 not cement
B14, B59 与 B21 不粘合

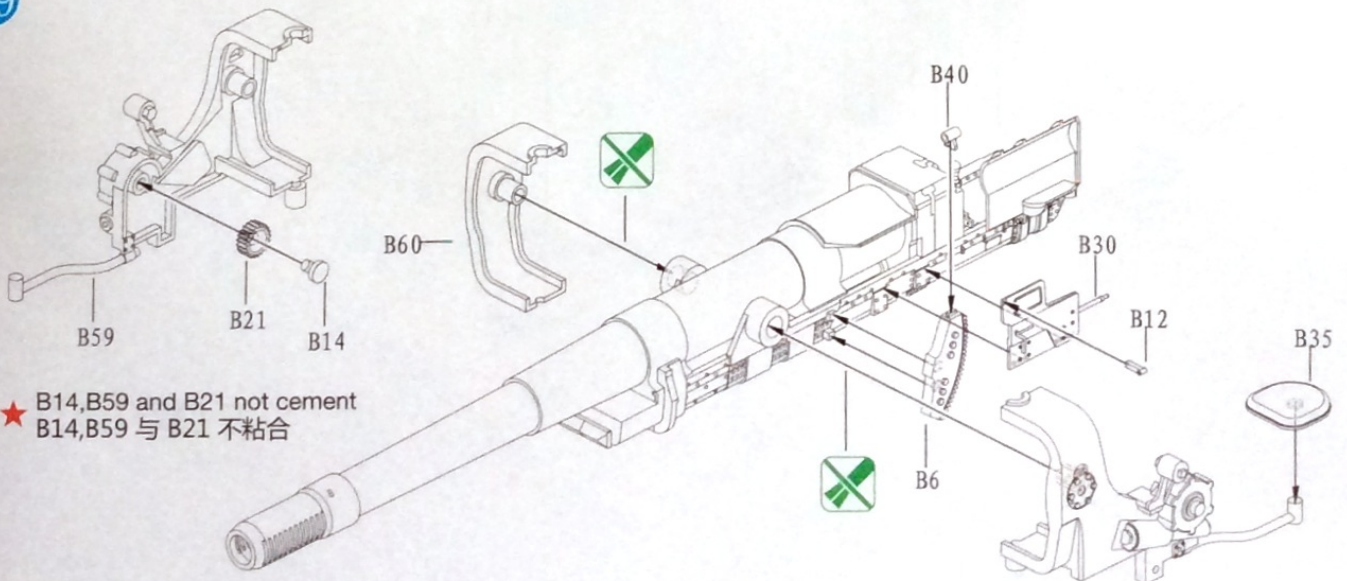

20

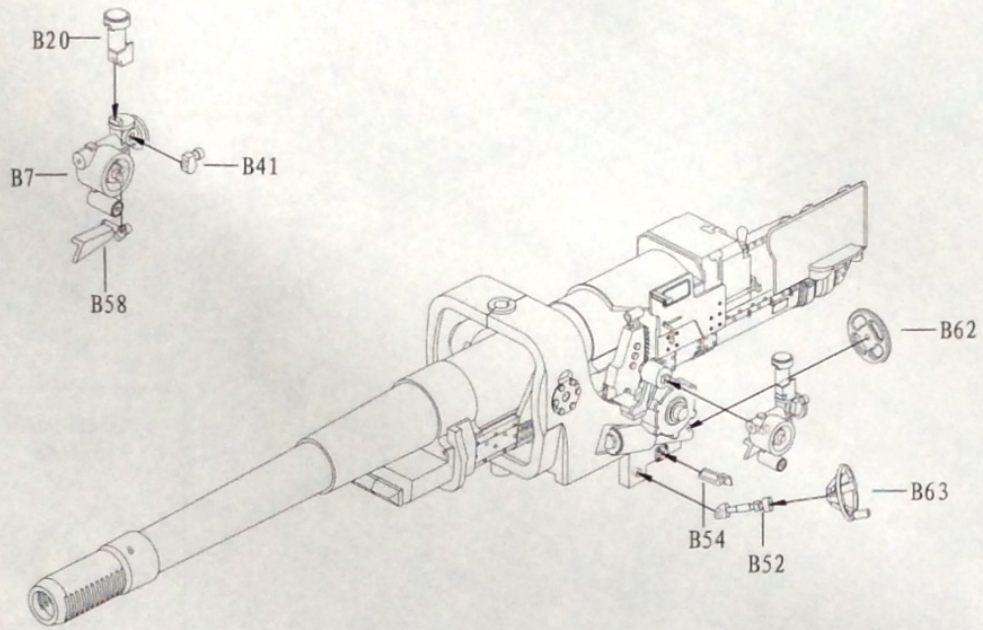

21

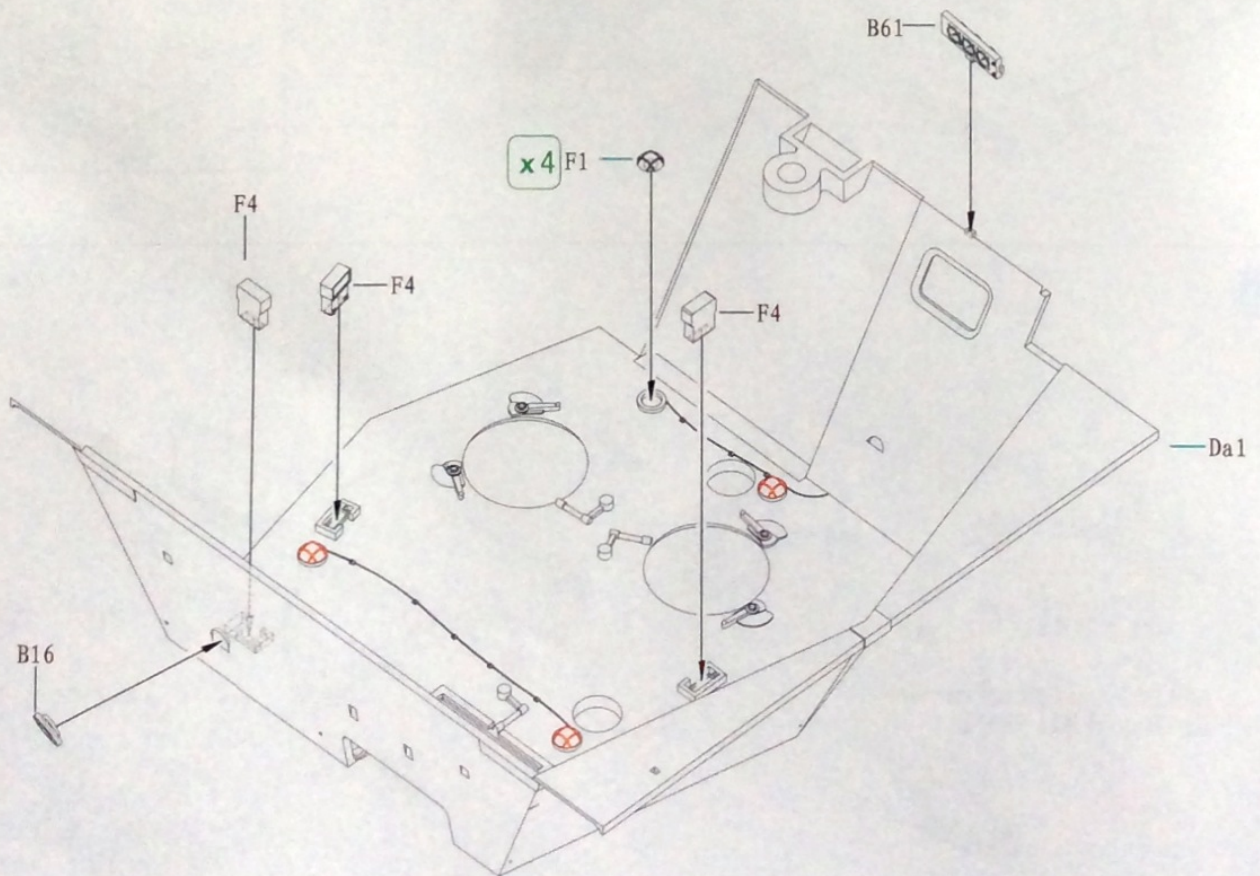

22

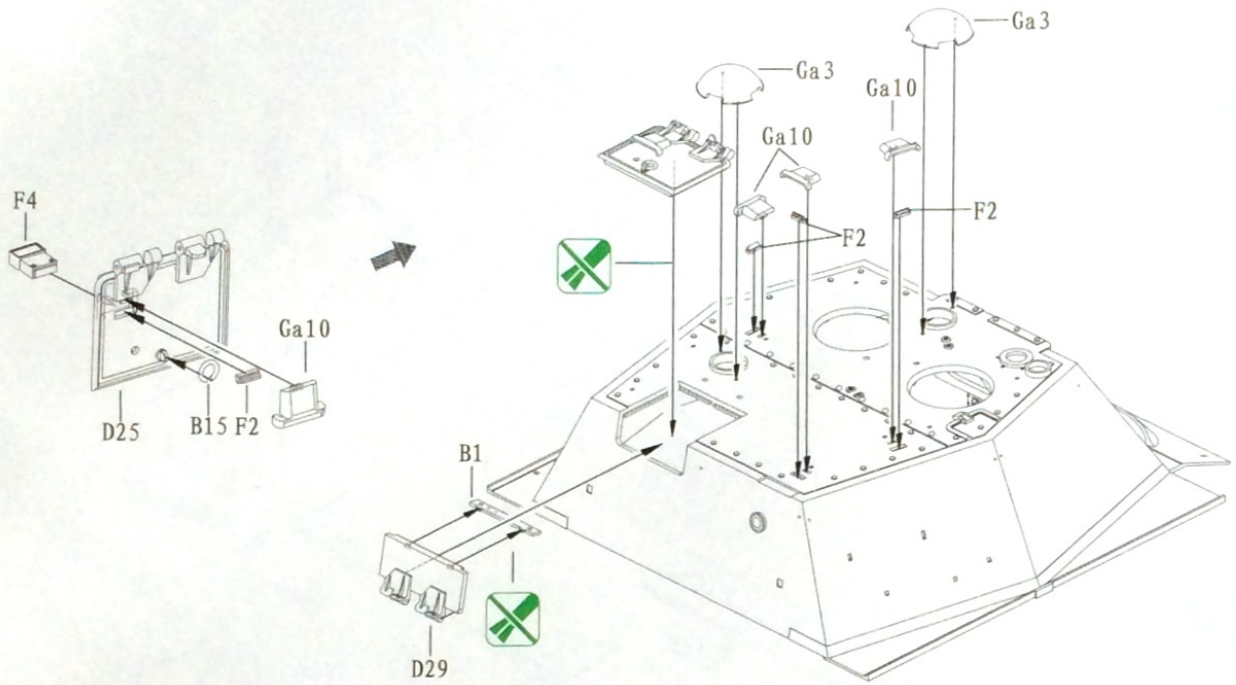

23

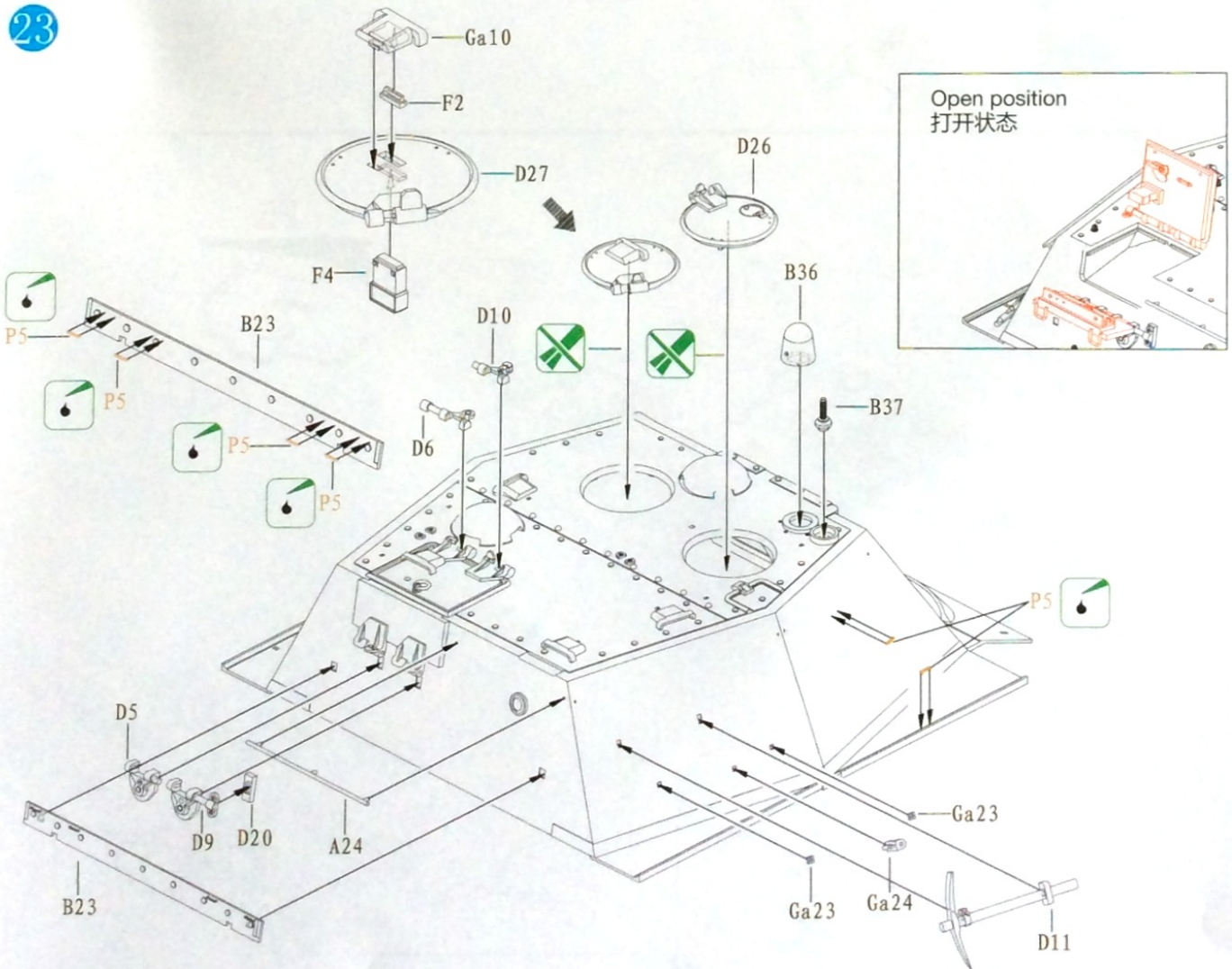
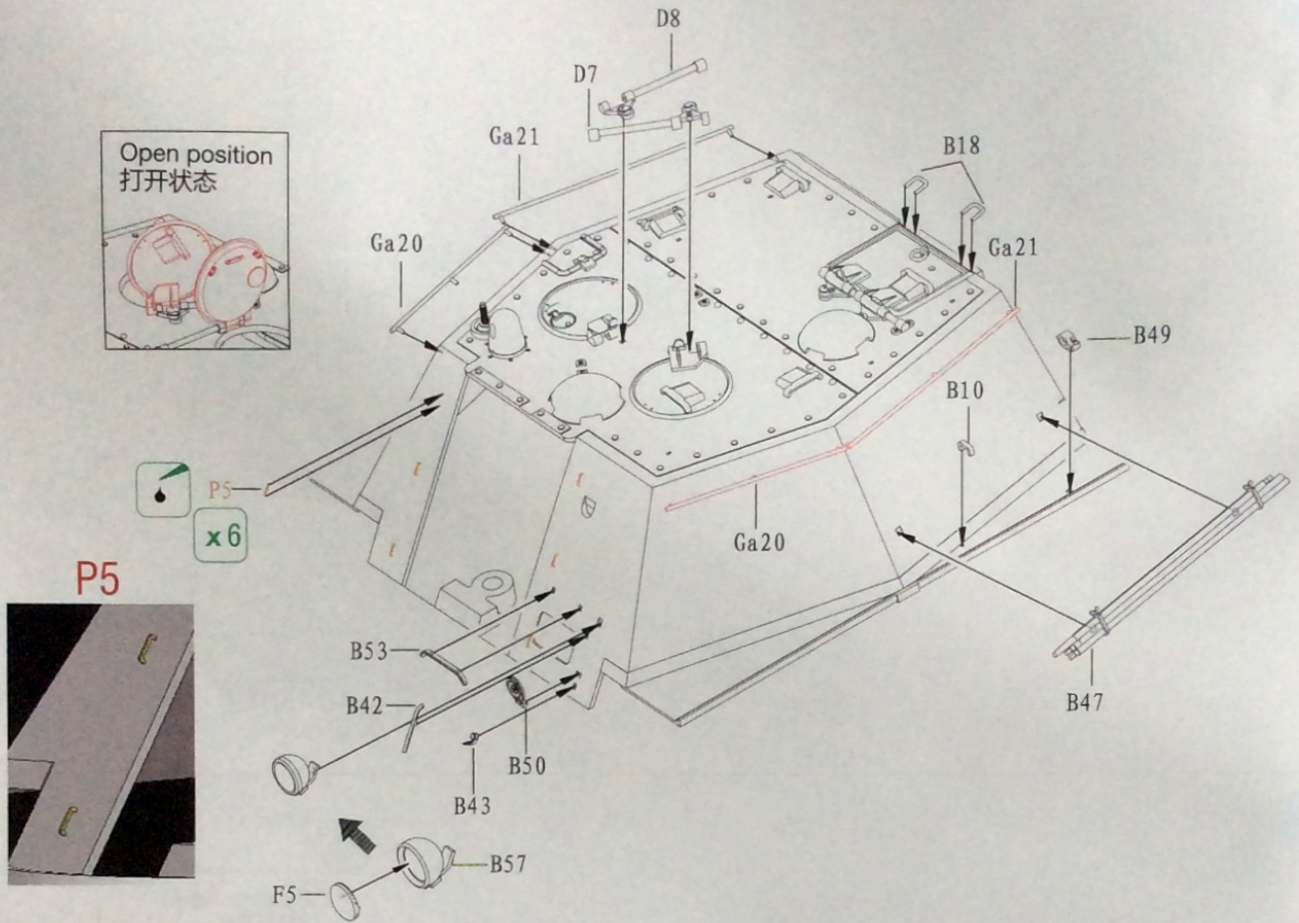
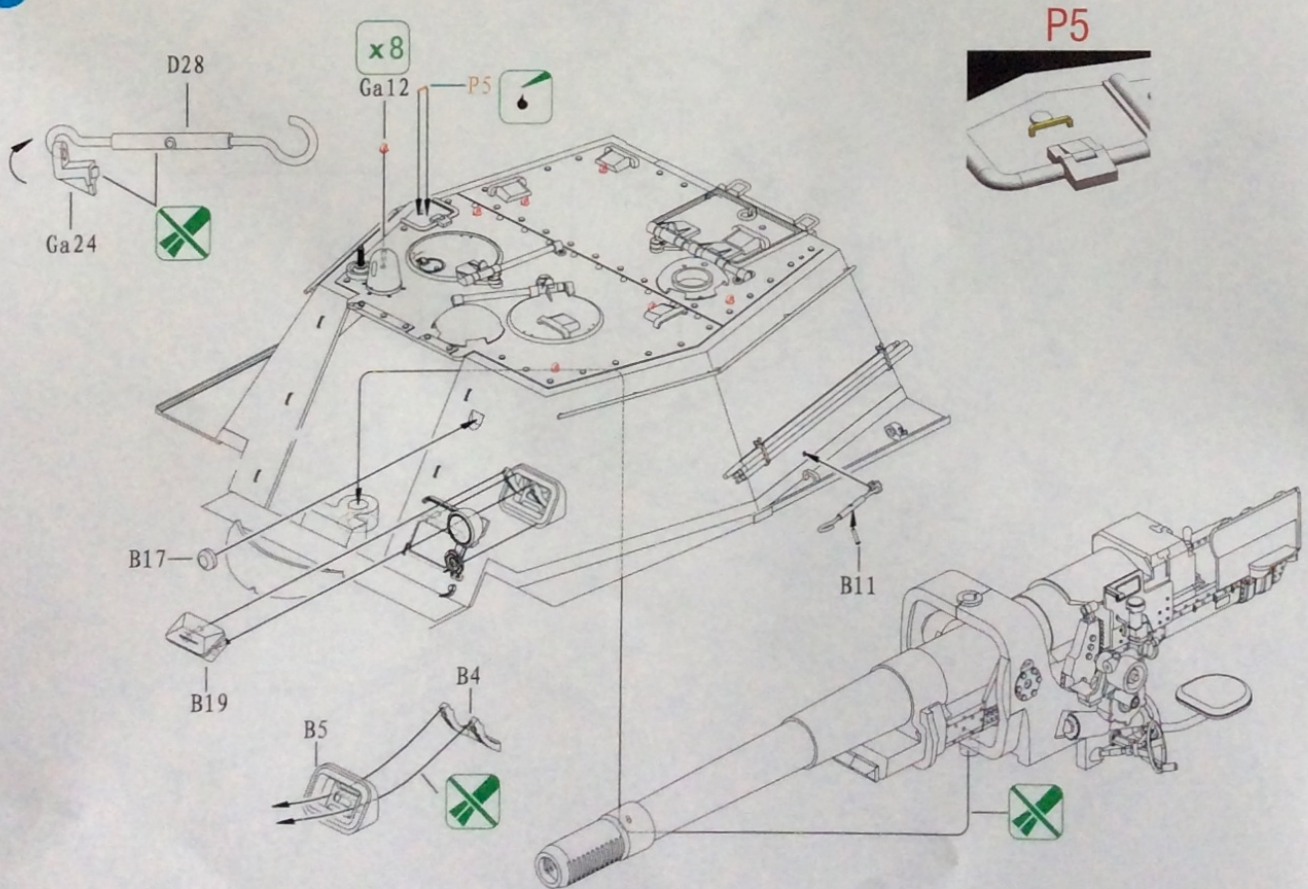

ILLUSTRATION 图示说明:

24



25



26

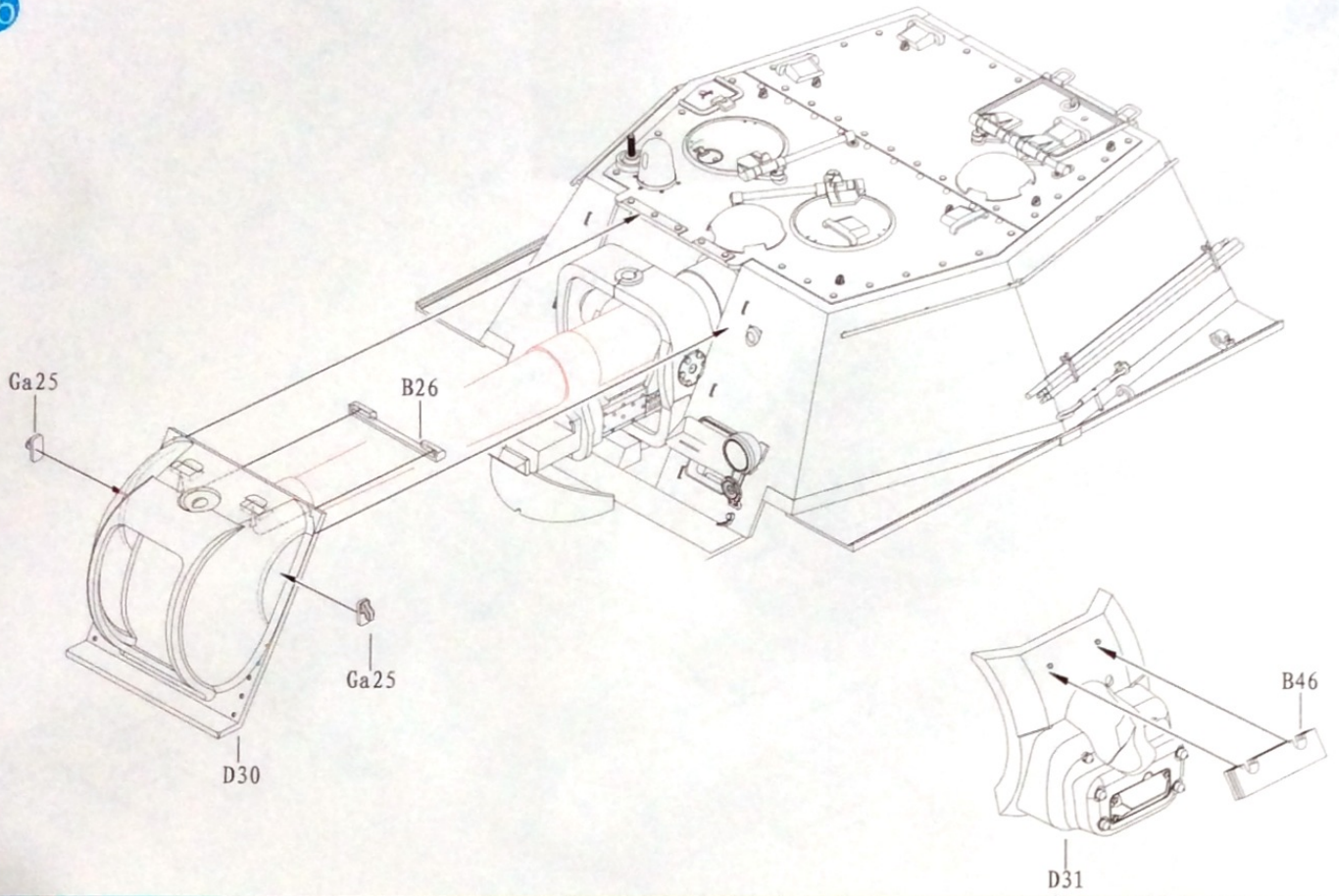

27

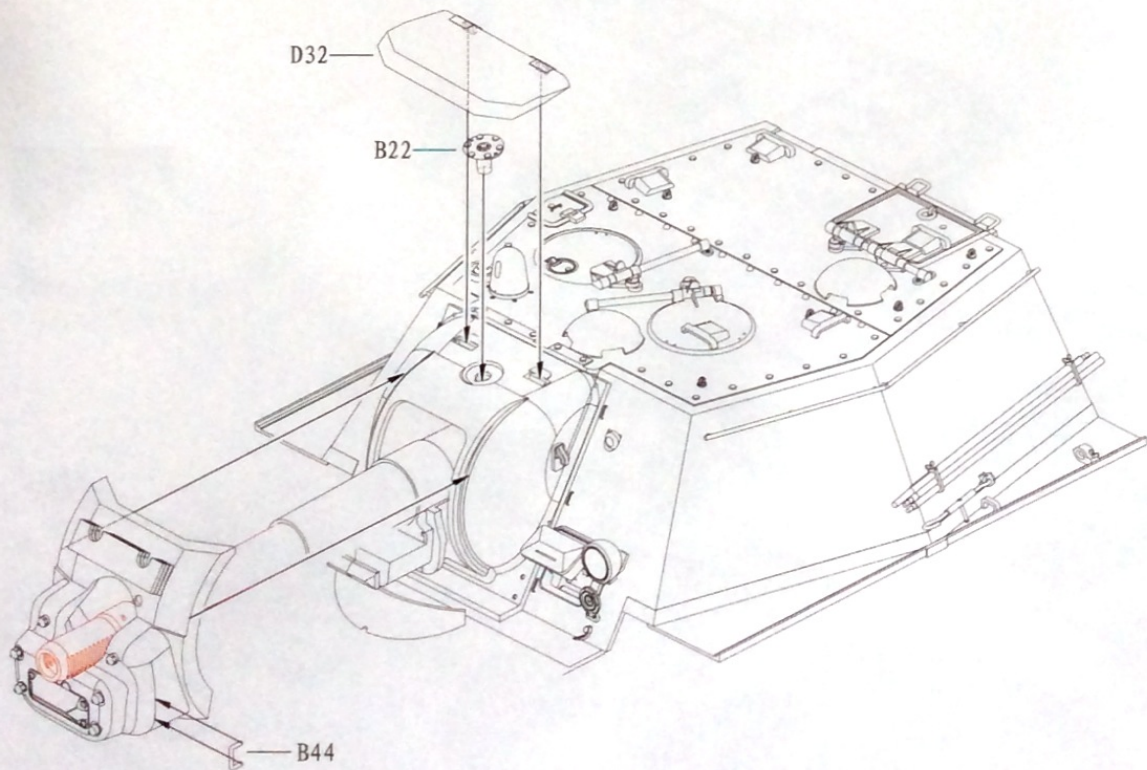
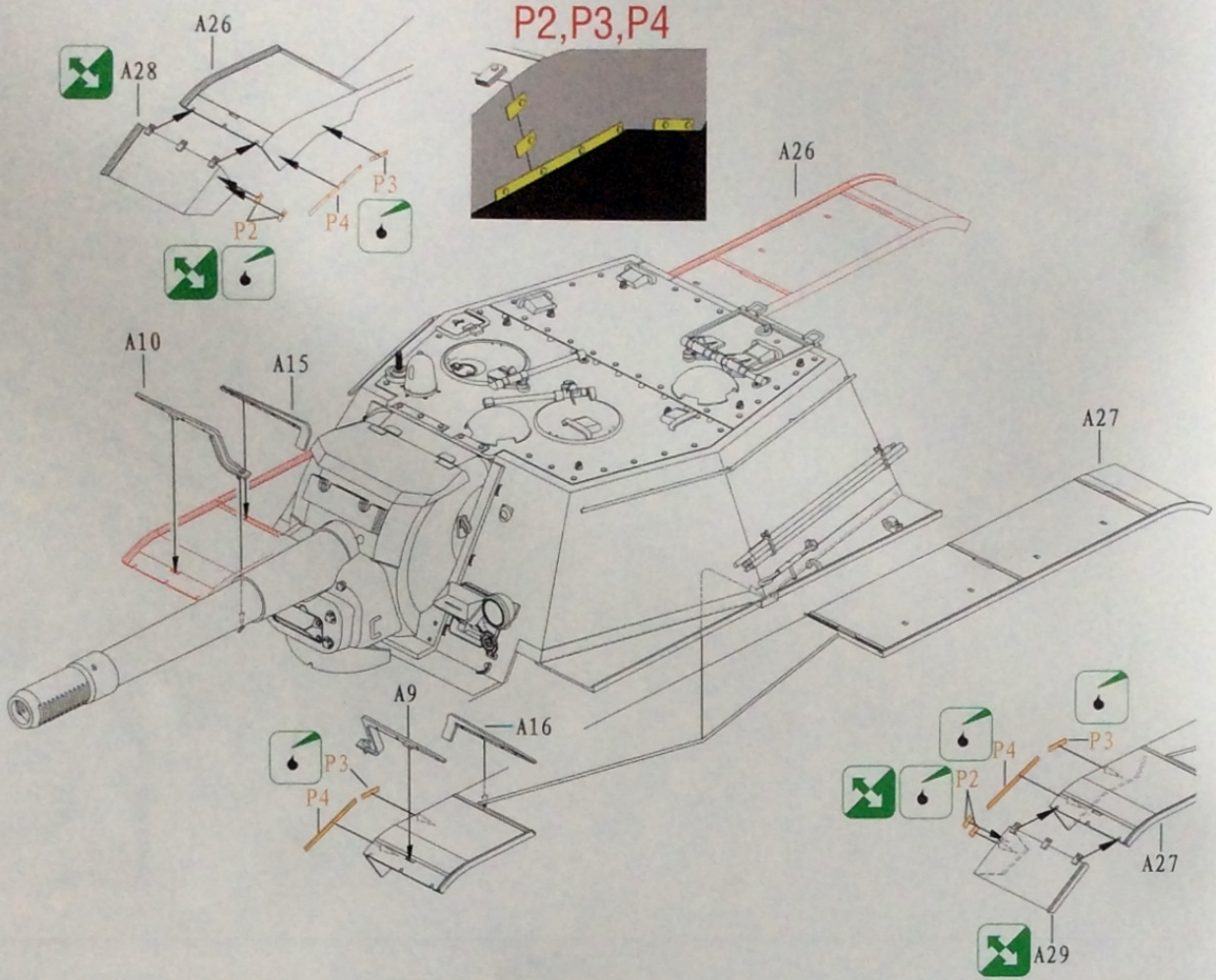
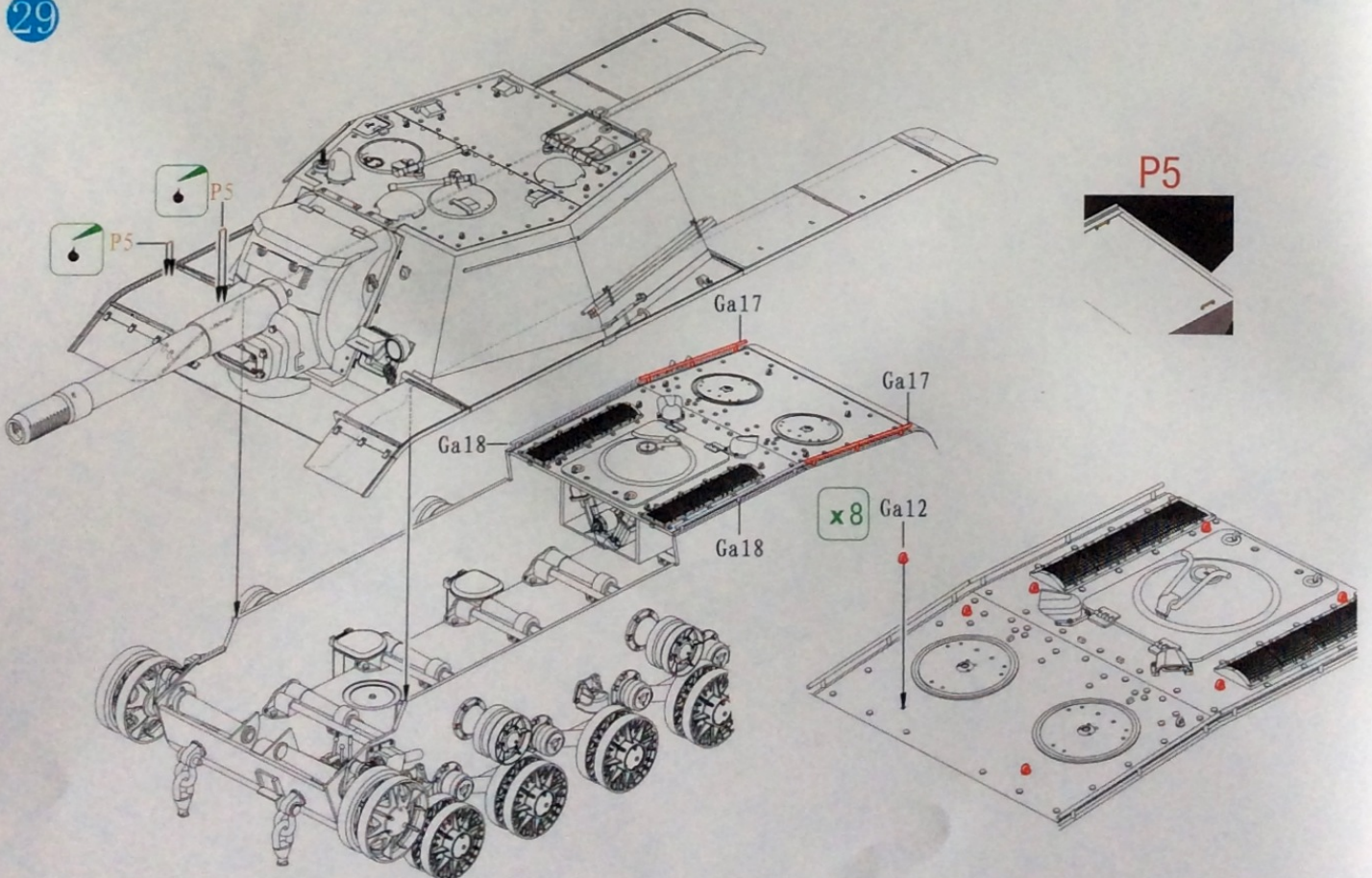

ILLUSTRATION 图示说明:

28



29



30

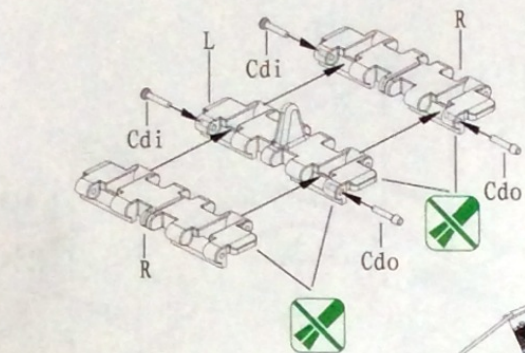

★ Caution: L Each set x44 pc
注意：L 每组需要44枚

★ Caution: R Each set x44 pc
注意：R 每组需要44枚

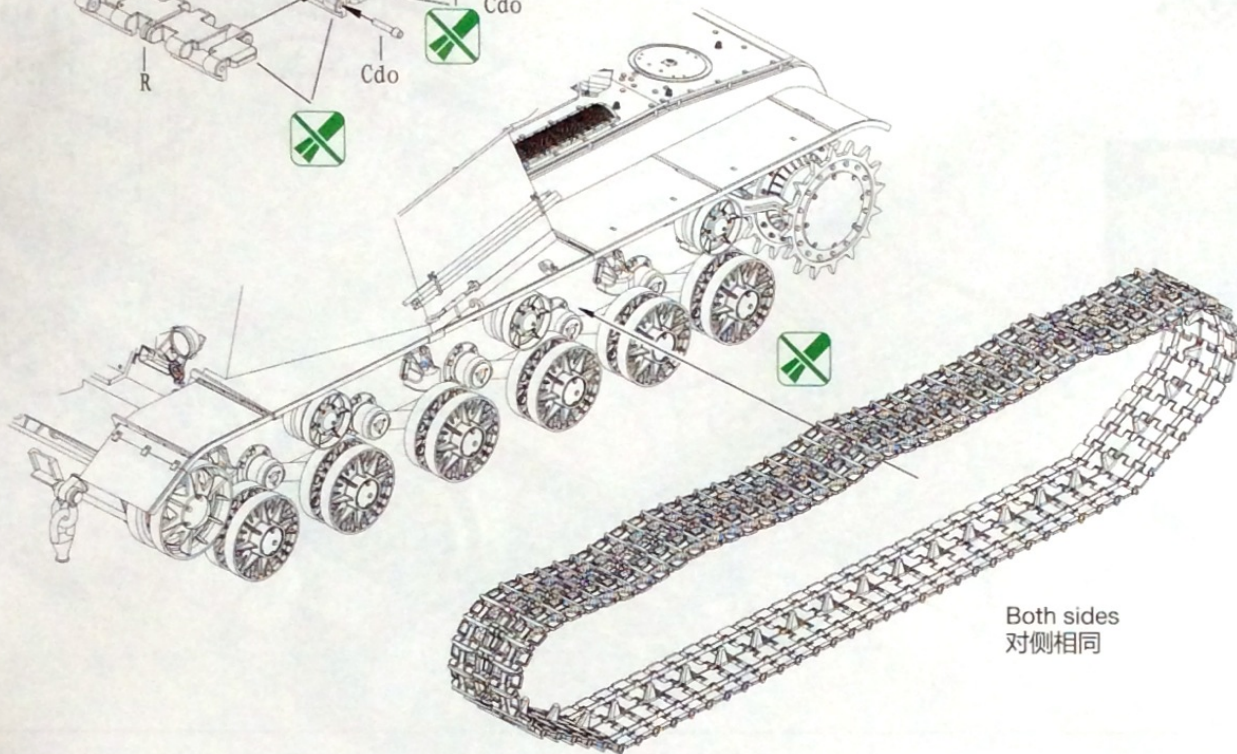

Both sides
对侧相同



31

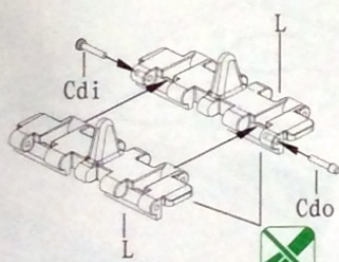

★ Caution: Each set x88 pc
注意：每组需要88枚

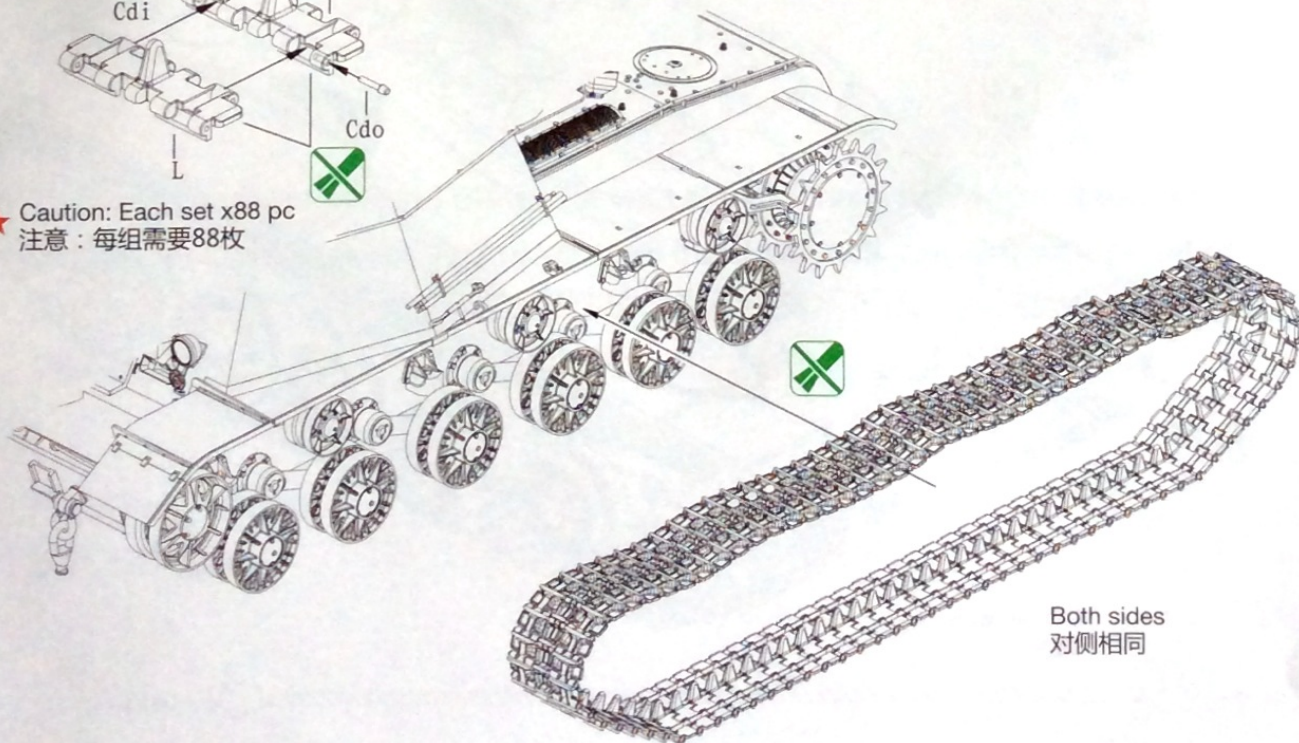

Both sides
对侧相同

ILLUSTRATION 图示说明:

32

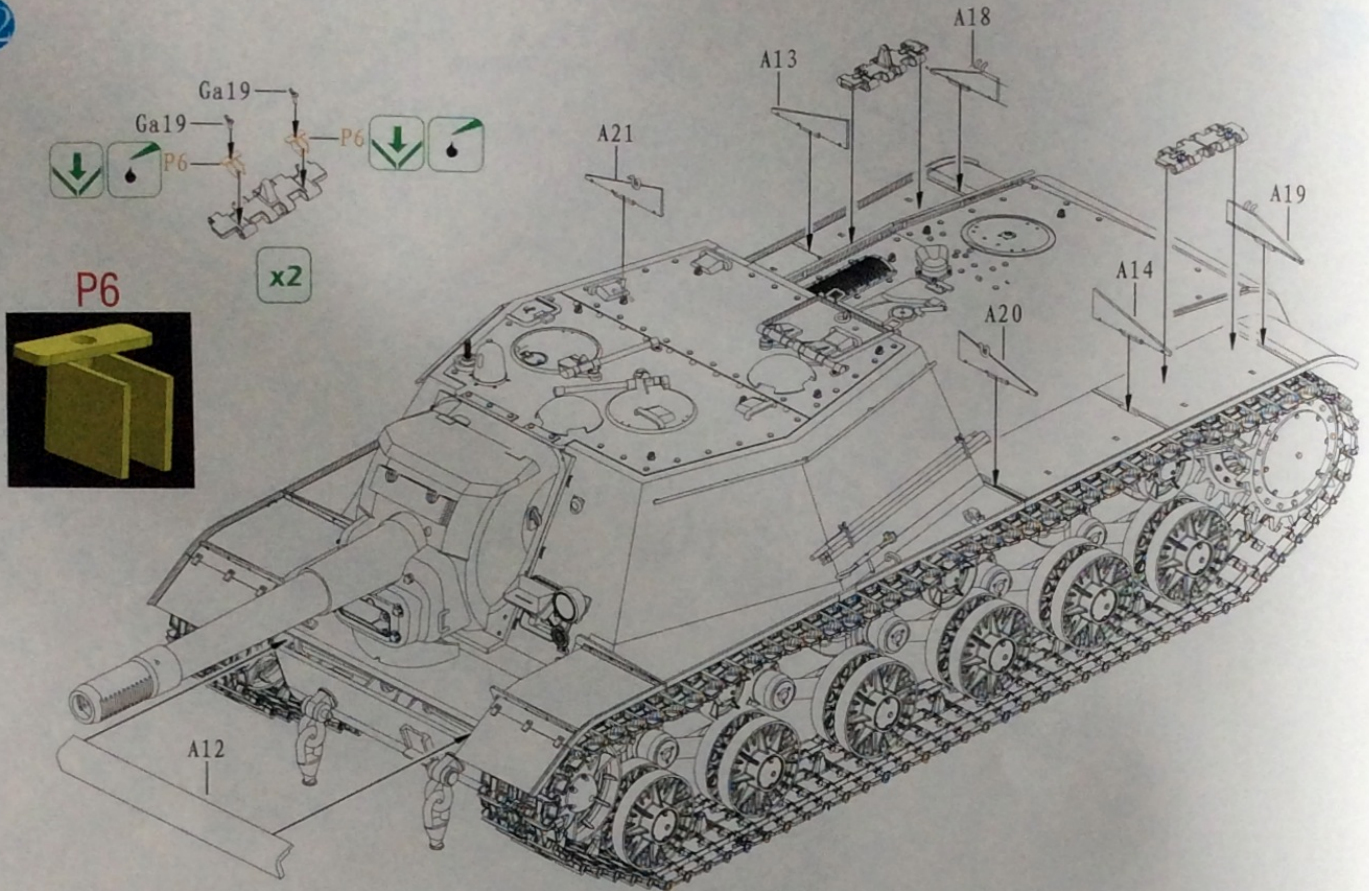

33

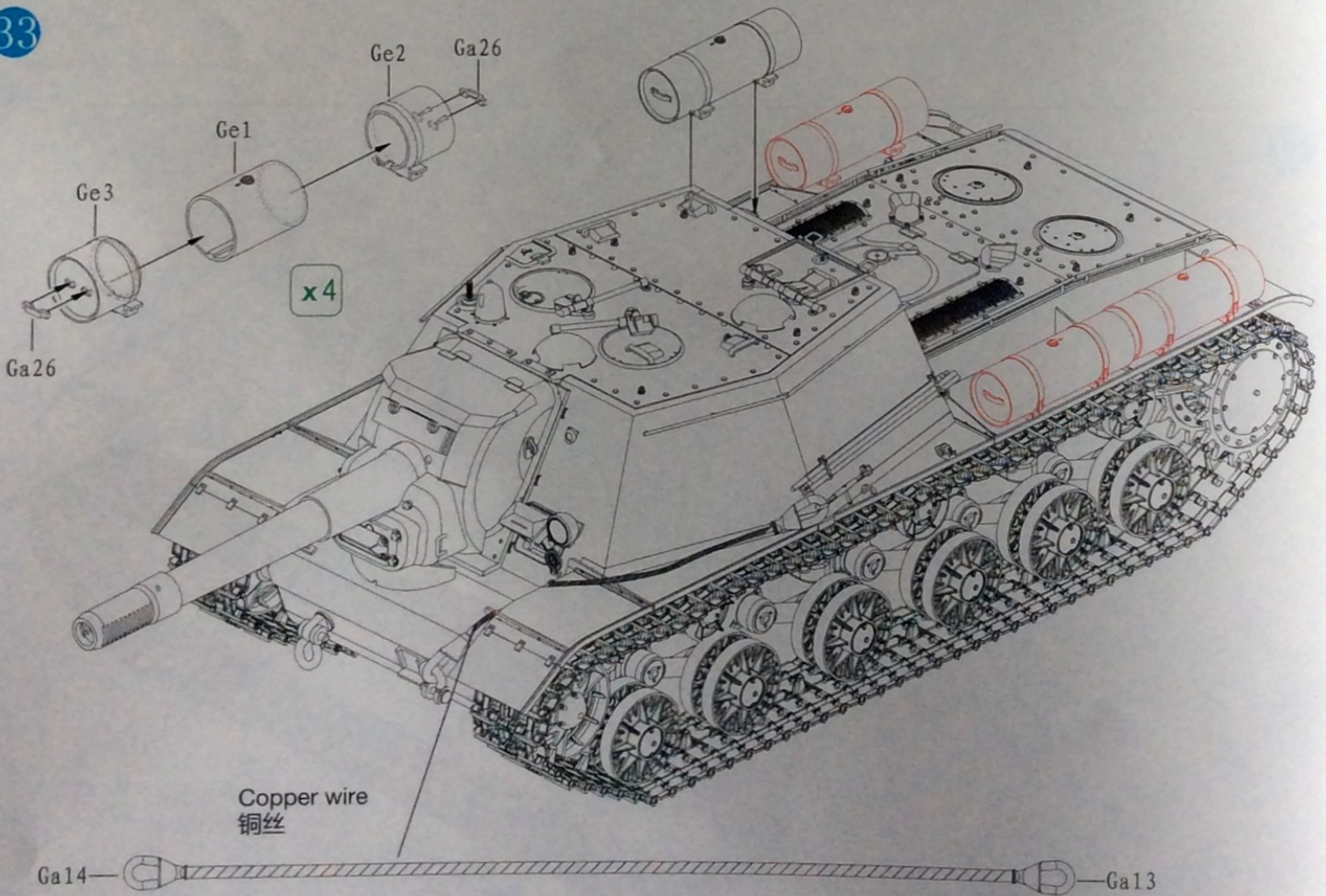

34

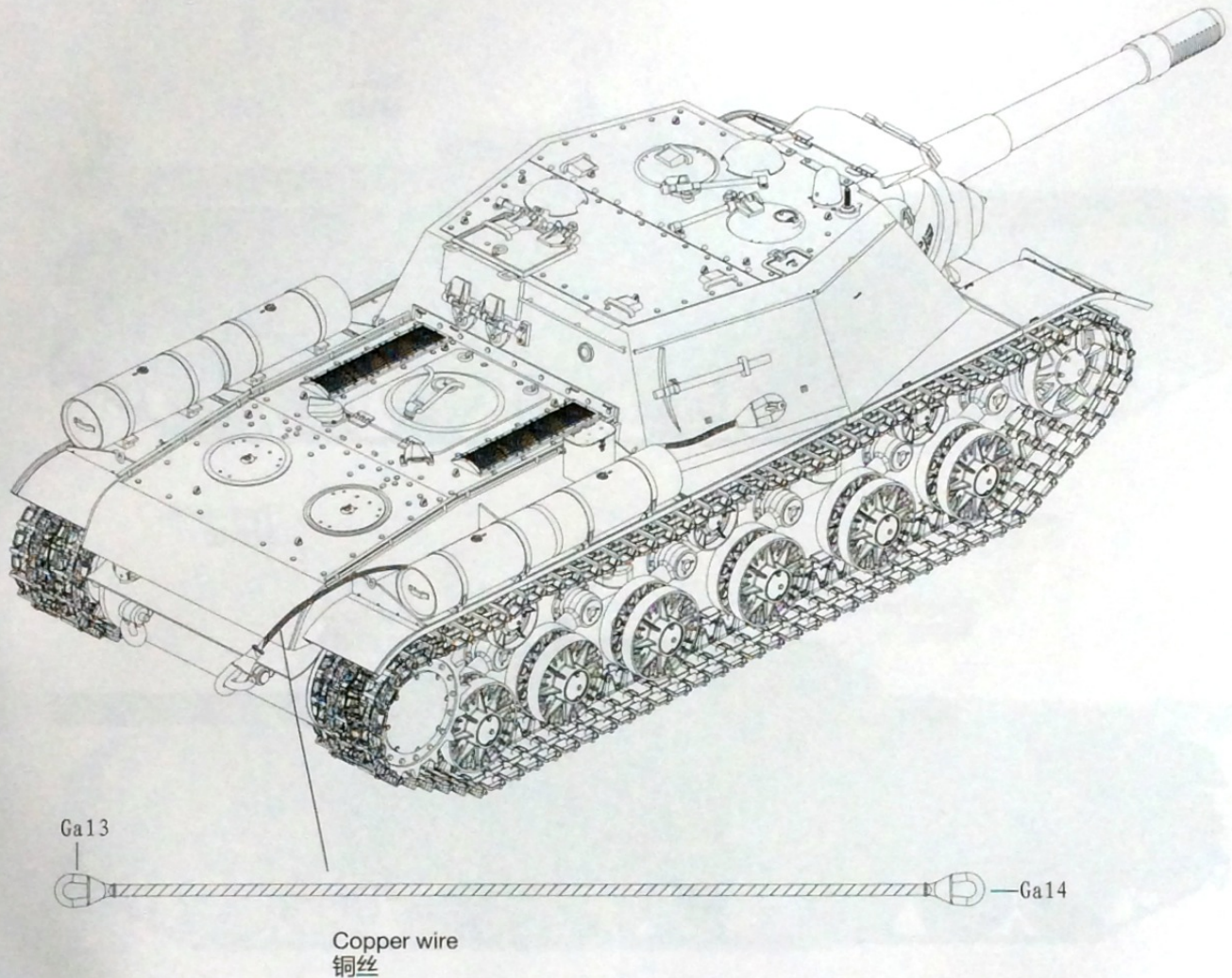

- ★ This is a precision molded plastic kit with exceptionally fine detail. It will require a little more care during assembly, but you feel the end result is well worth the effort.
 本套件设计精密,零件繁多可能让你在制作过程中有所不便,但完成后会让你产生无穷之成功快感。

Happy modelling!
 祝愿制作愉快!

DECAL & COLOUR GUIDE 水贴及涂色指示:

Option1: SU-152 (Sept,1943 Production) SP Gun , Unidentified Unit ,Eastern Front, Summer 1944.
 1944年夏天,在东部战线作战之SU-152(1943年9月生产型)自走炮。

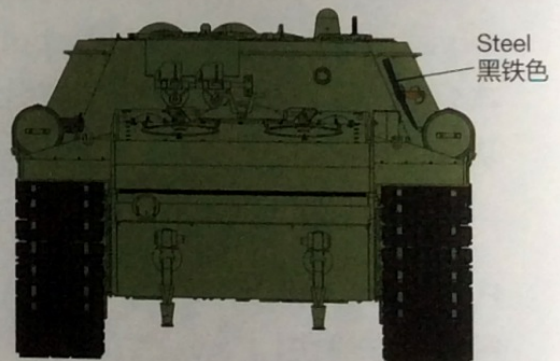
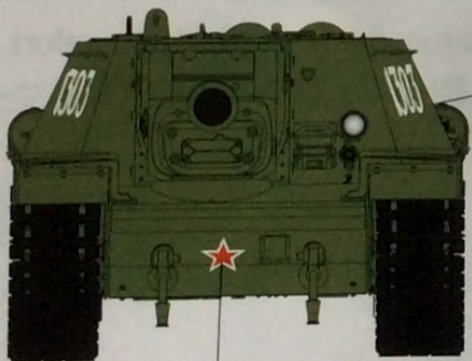

DECAL & COLOUR GUIDE 水贴及涂色指示:

Option2: SU-152 (Sept, 1943 Production) SP Gun , Unidentified Unit , Eastern Front, Spring 1944.
 1944年春天, 在东部战线作战之SU-152(1943年9月生产型)自走炮。



DECAL & COLOUR GUIDE 水贴及涂色指示:

Option3:

German Captured SU-152 (Sept, 1943 Production) SP Gun From Unidentified Unit, Eastern Front, February-March 1944
 1944年2-3月之间,在东部战线遭德军捕获再予以使用之SU-152(1943年9月生产型)自走炮(部队单位不明)。

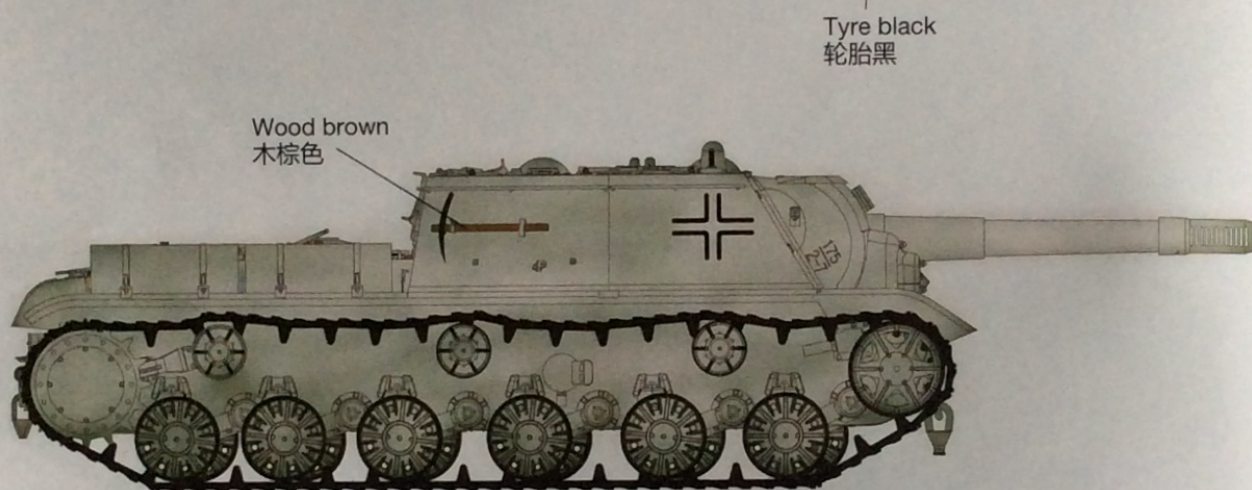
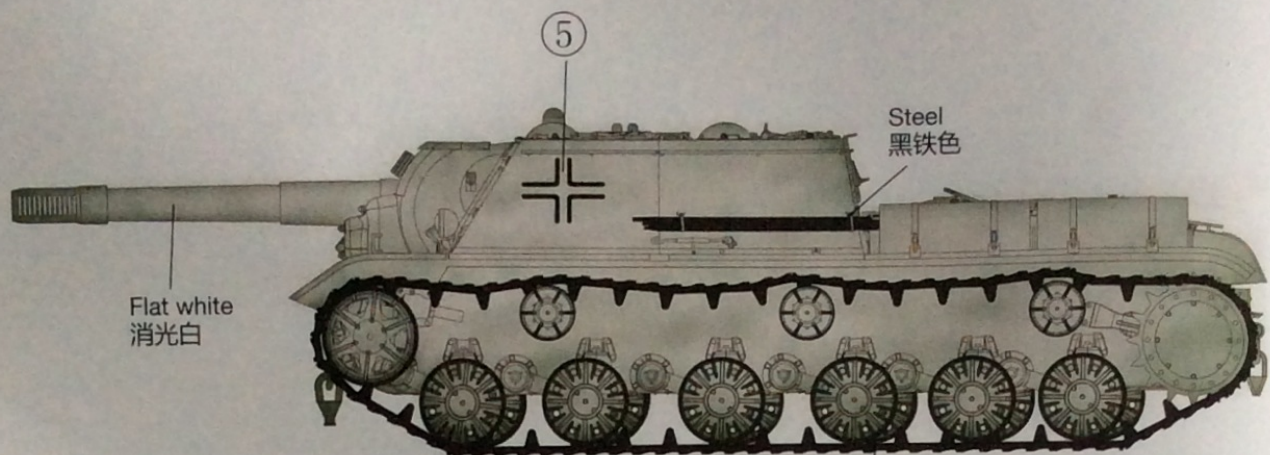

Black or Track Color 履带色

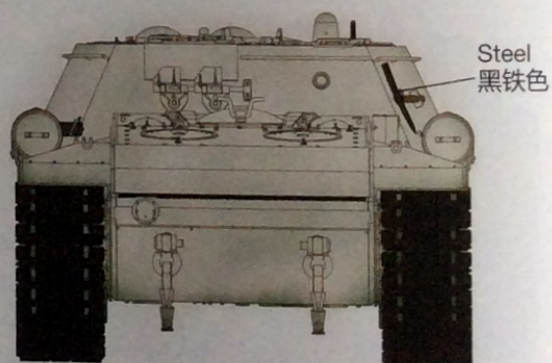
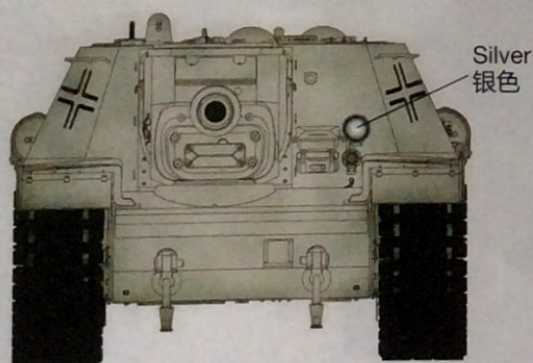

DECAL & COLOUR GUIDE 水贴及涂色指示:

Option4: SU-152 SP (Sept, 1943 Production) Gun From Unidentified Unit, Kharkov In, September 1943.
 1943年9月, 在乌克兰哈尔科夫作战之SU-152(1943年9月生产型)自走炮(部队单位不明)。



DECAL & COLOUR GUIDE 水贴及涂色指示:

Option5: SU-152 (Sept, 1943 Production) SP Gun From Unidentified Unit, Eastern Front, March 1944.
 1944年3月, 在东部战线作战之SU-152(1943年9月生产型)自走炮(部队单位不明)。

